

HYDRAULIC MOTORS PL

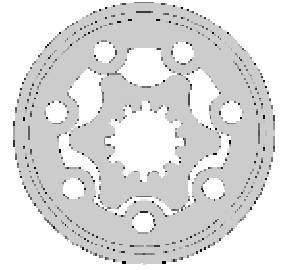

APPLICATION

- » Conveyors
- » Feeding mechanism of robots and manipulators
- » Metal working machines
- » Textile machines
- » Machines for agriculture
- » Food industries
- » Mining machinery etc.



CONTENTS

Specification data 5
 Function diagrams6÷10
 Permissible shaft loads 10
 Dimensions and mounting ... 11
 Shaft extensions 12
 Order code 13

OPTIONS

- » Model- Spool valve, gerotor
- » Antifriction conical bearing
- » Flange mount
- » Shafts- straight, splined and tapered
- » Metric and BSPP ports
- » Other special features

GENERAL

Displacement, [cm ³ /rev.]	49,5÷396
Max. Speed, [RPM]	150÷1210
Max. Torque, [daNm]	9,4÷50
Max. Output, [kW]	9,9÷11,7
Max. Pressure Drop, [bar]	95÷140
Max. Oil Flow, [l/min]	60
Min. Speed, [RPM]	10
Permissible Shaft Loads, [daN]	P _a =500
Pressure fluid	Mineral based- HLP(DIN 51524) or HM(ISO 6743/4)
Temperature range, [°C]	-30÷90
Optimal Viscosity range, [mm ² /s]	20÷75
Filtration	ISO code 20/16 (Min. recommended fluid filtration of 25 micron)

Oil flow in drain line

Pressure drop (bar)	Viscosity (mm ² /s)	Oil flow in drain line (l/min)
100	20	2,5
	35	1,8
140	20	3,5
	35	2,8

Pressure Losses

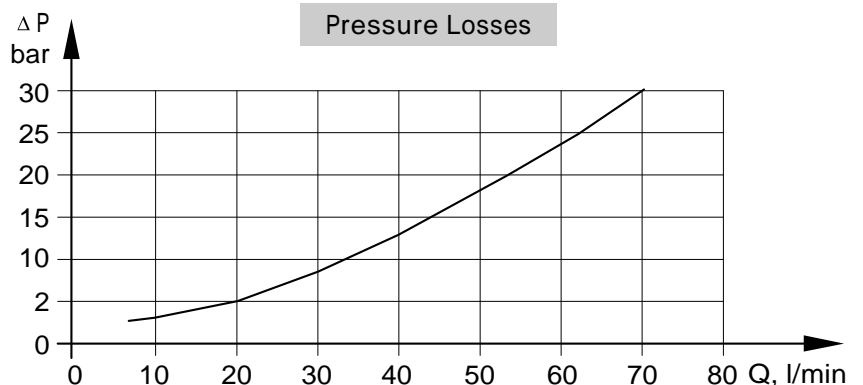



SPECIFICATION DATA

Type	PL 50	PL 80	PL 100	PL 125	PL 160	PL 200	PL 250	PL 315	PL 400	
Displacement, [cm. ³ /rev.]	49,5	79,2	99	123,8	158,4	198	247,5	316,8	396	
Max. Speed, [RPM]	Cont.	1210	755	605	485	378	303	242	190	150
	Int.*	1515	945	755	605	472	378	303	236	189
Max. Torque [daNm]	Cont.	9,4	15,1	19,3	23,7	31,3	36,6	47,0	48,6	50,0
	Int.*	11,9	19,5	23,7	29,8	37,8	45,6	58,3	56,0	59,0
	Peak**	14,0	22,0	27,0	36,5	42	53,0	67,0	85,0	85,4
Max. Output [kW]	Cont.	9,9	9,9	9,9	9,9	11,7	10,3	9,8	7,6	6,6
	Int.*	12,5	12,5	12,5	12,5	12,5	15,5	17,5	8,2	9,2
Max. Pressure Drop [bar]	Cont.	140	140	140	140	140	140	140	120	95
	Int.*	175	175	175	175	175	175	175	140	115
	Peak**	225	225	225	225	225	225	225	225	180
Max. Oil Flow [l/min]	Cont.	60	60	60	60	60	60	60	60	60
	Int.*	75	75	75	75	75	75	75	75	75
Max. Inlet Pressure [bar]	Cont.	175	175	175	175	175	175	175	175	175
	Int.*	200	200	200	200	200	200	200	200	200
	Peak**	225	225	225	225	225	225	225	225	225
Max. Return Pressure without Drain Line or Max. Pressure in Drain Line, [bar]	Cont. 0-100 RPM	100	100	100	100	100	100	100	100	100
	Cont. 100-300 RPM	50	50	50	50	50	50	50	50	50
	Cont. 300-600 RPM	25	25	25	25	25	25	25	25	25
	Cont. >600 RPM	15	15	15	15	15	15	15	15	15
	Int.* 0-max. RPM	100	100	100	100	100	100	100	100	100
Max. Return Pressure with Drain Line [bar]	Cont.	175	175	175	175	175	175	175	175	175
	Int.*	200	200	200	200	200	200	200	200	200
	Peak**	225	225	225	225	225	225	225	225	225
Max. Starting Pressure with Unloaded Shaft, [bar]	10	10	10	9	8	7	6	5	5	
Min. Starting Torque [daNm]	7,7	14,0	16,8	21,0	28,0	32,2	41,4	43,0	44,0	
Min. Speed***, [RPM]	10	10	10	10	10	10	10	10	10	
Weight, [kg]	8,4	8,5	8,8	8,9	9,1	9,5	10,0	10,7	11,4	

* Intermittent operation: the permissible values may occur for max. 10% of every minute.

** Peak load: the permissible values may occur for max. 1% of every minute.

*** For speeds of 10 RPM or lower, consult factory or your regional manager.

1. Intermittent speed and intermittent pressure drop must not occur simultaneously.
2. Recommended filtration is per ISO cleanliness code 20/16. A nominal filtration of 25 micron or better.
3. Recommended using a premium quality, anti-wear type mineral based hydraulic oil HLP(DIN51524) or HM (ISO 6743/4).
If using synthetic fluids consult the factory for alternative seal materials.
4. Recommended minimum oil viscosity 13 mm²/s at operating temperatures.
5. Recommended maximum system operating temperature is 82°C.
6. To assure optimum motor life fill with fluid prior to loading and run at moderate load and speed for 10-15 minutes.

FUNCTION DIAGRAMS

PL 50

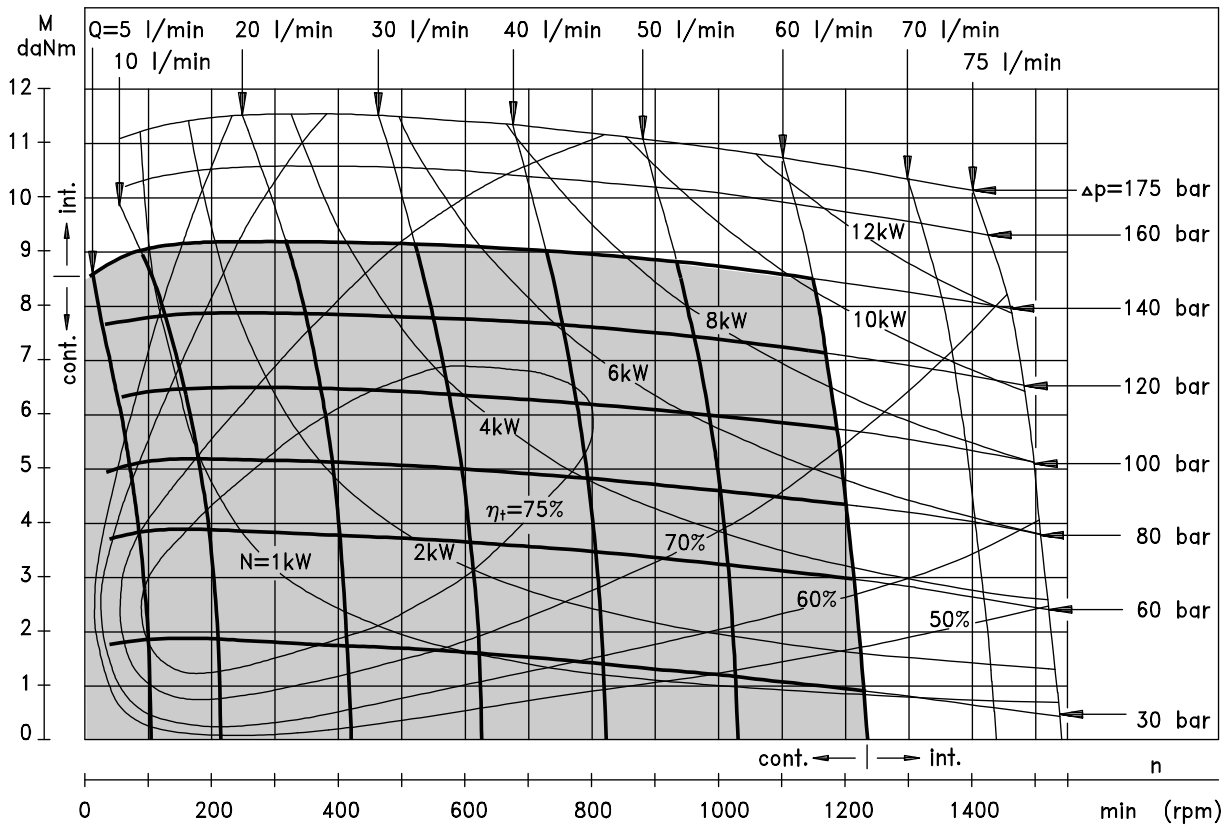

PL 80

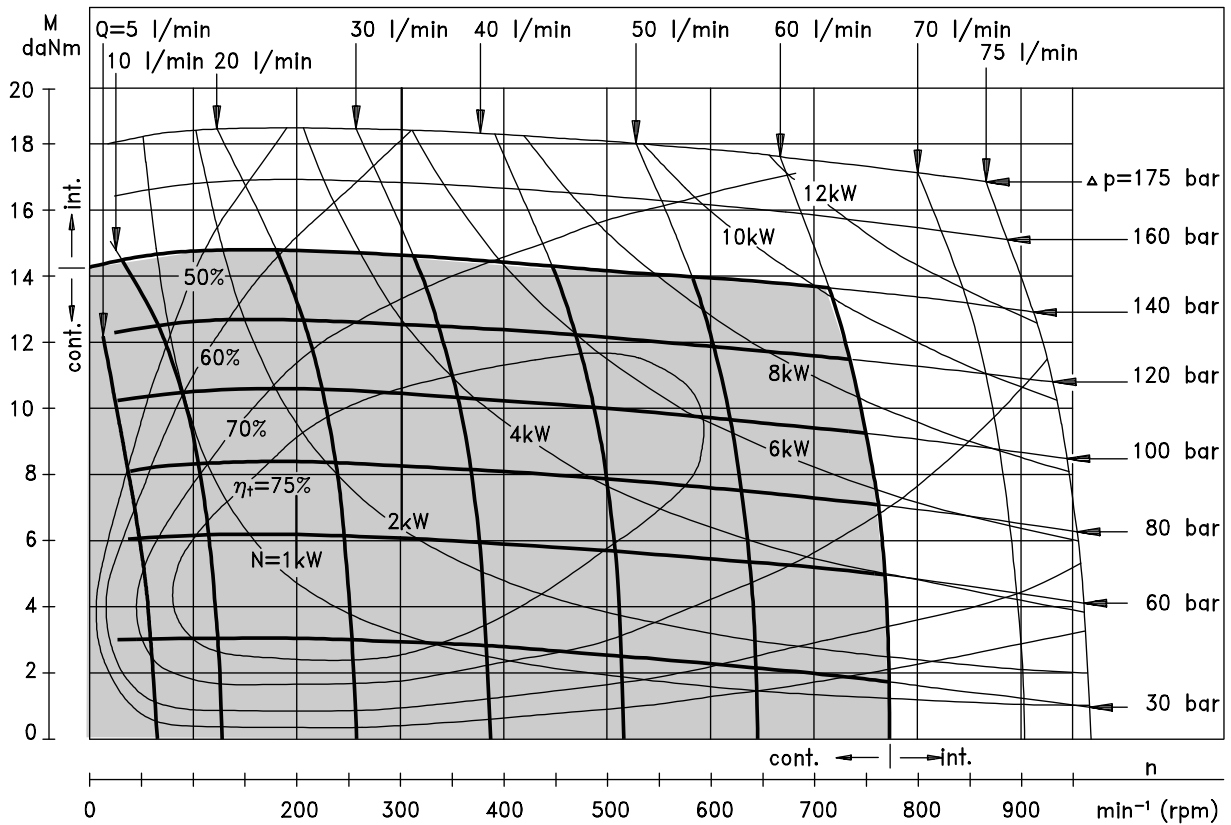

The function diagrams data was collected at back pressure 5÷10 bar and oil with viscosity of 32 mm^2/s at 50° C.

FUNCTION DIAGRAMS

PL 100

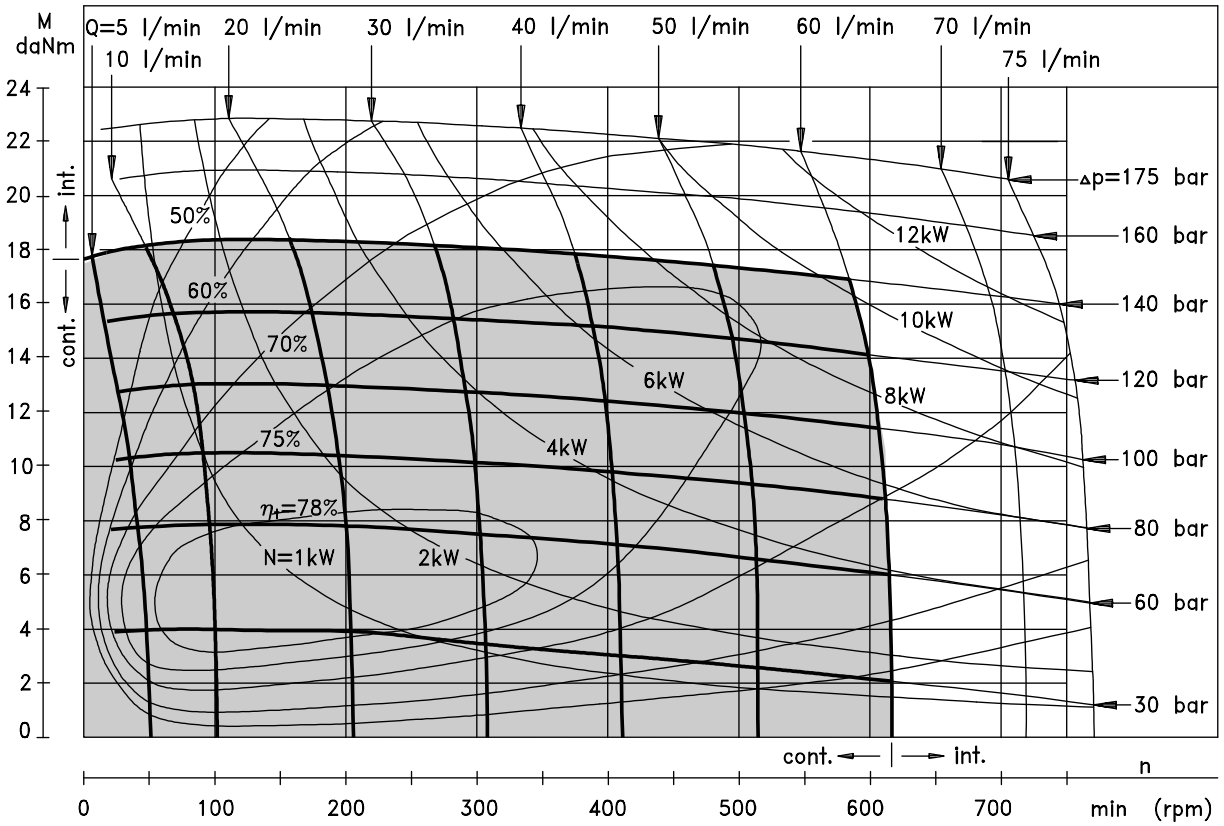

PL 125

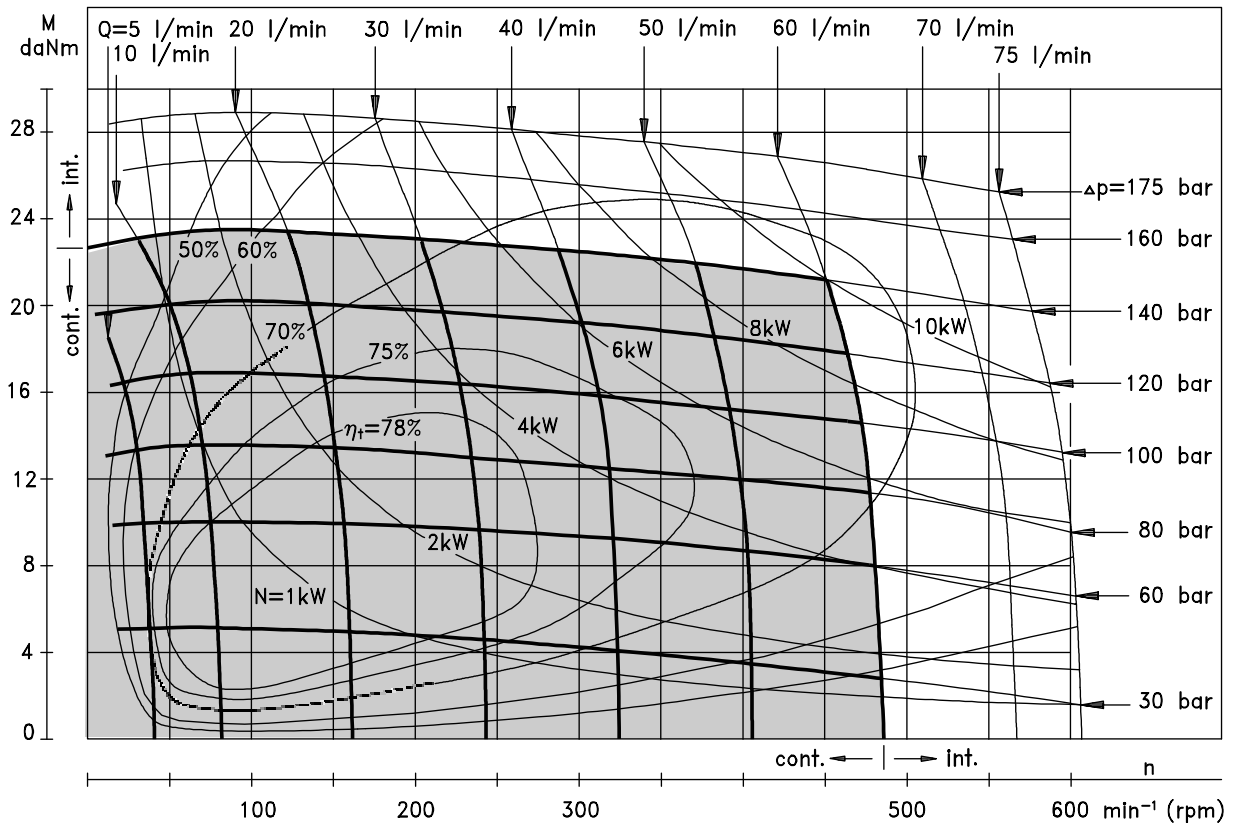

The function diagrams data was collected at back pressure 5÷10 bar and oil with viscosity of 32 mm²/s at 50° C.

FUNCTION DIAGRAMS

PL 160

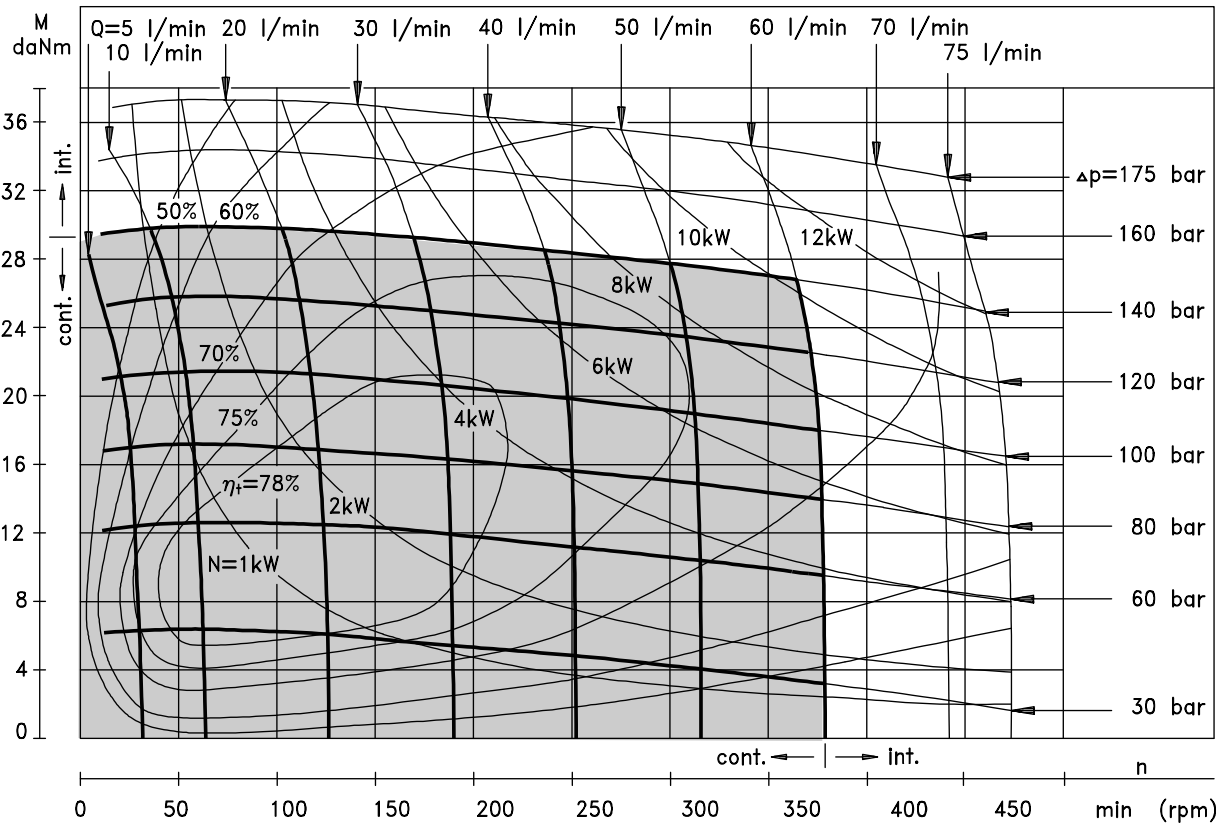

PL 200

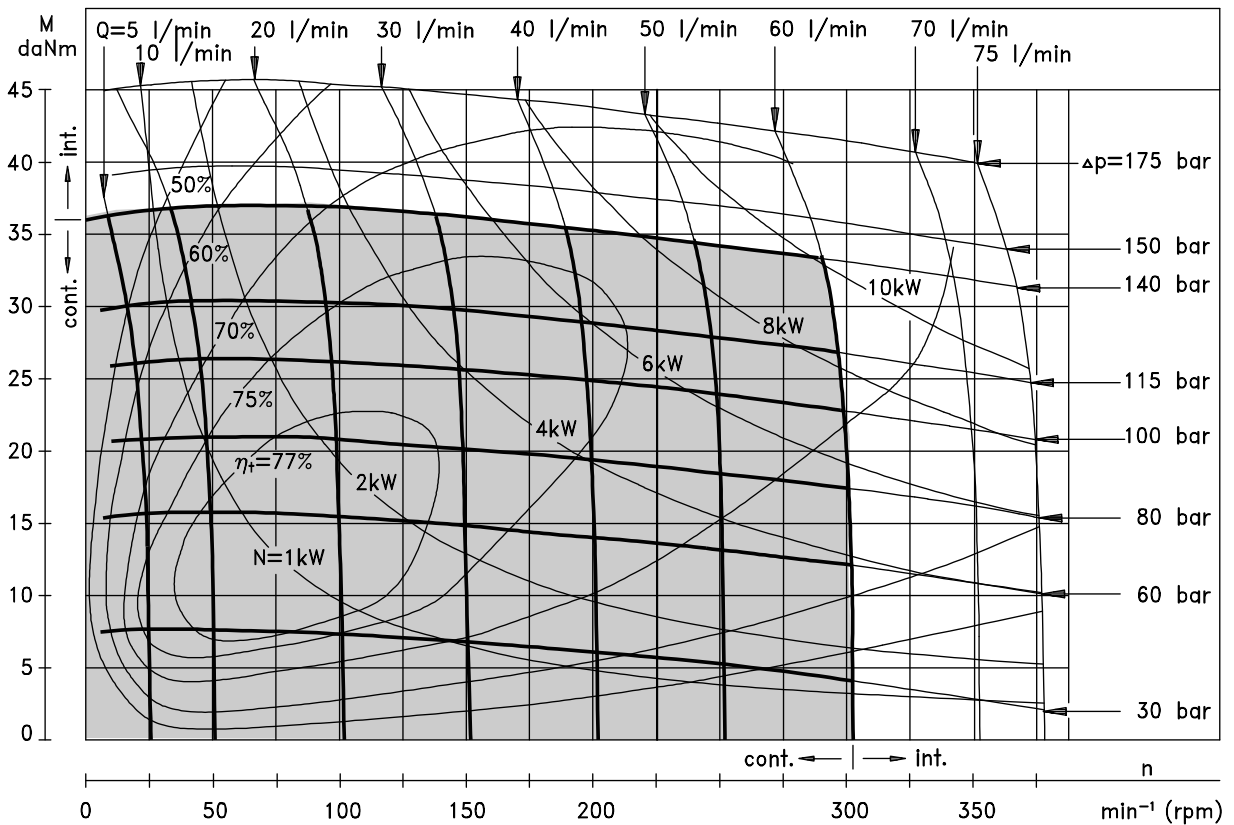

The function diagrams data was collected at back pressure 5÷10 bar and oil with viscosity of 32 mm²/s at 50° C.

FUNCTION DIAGRAMS

PL 250

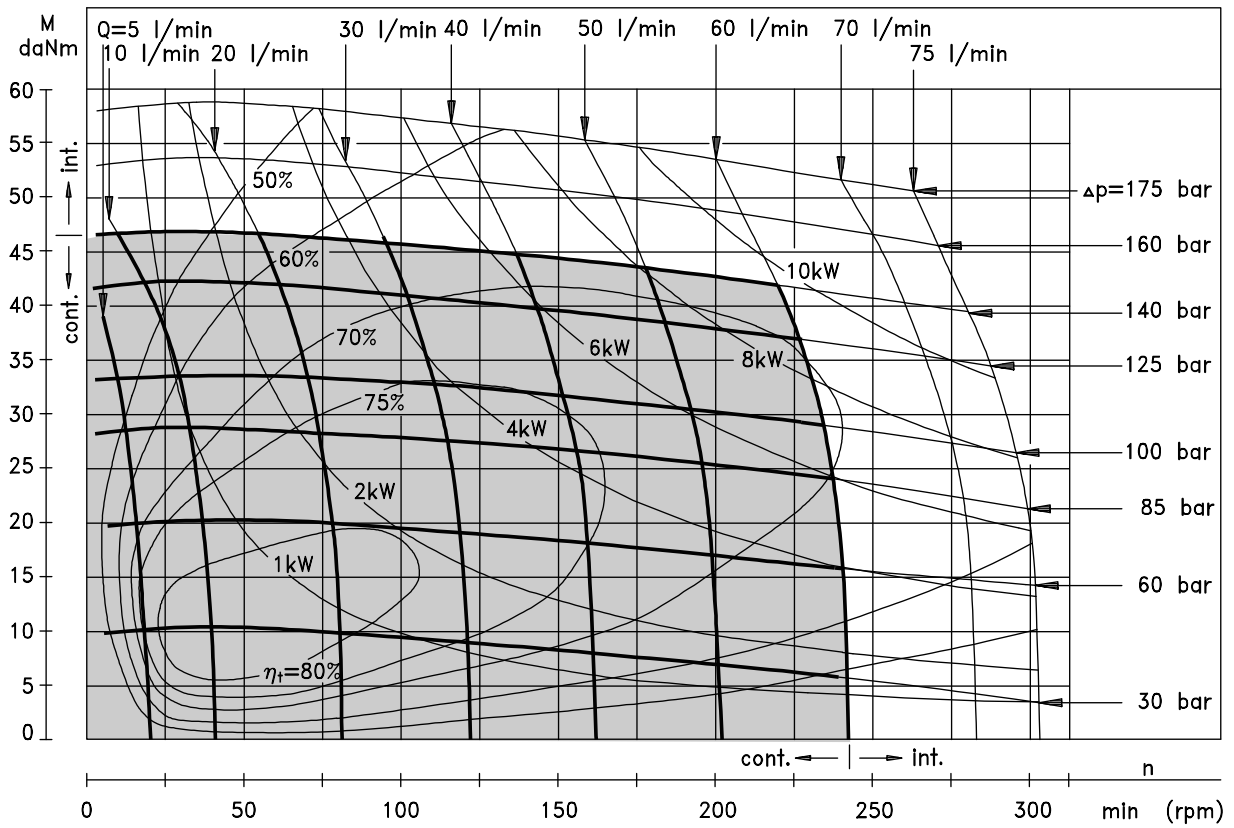

PL 315

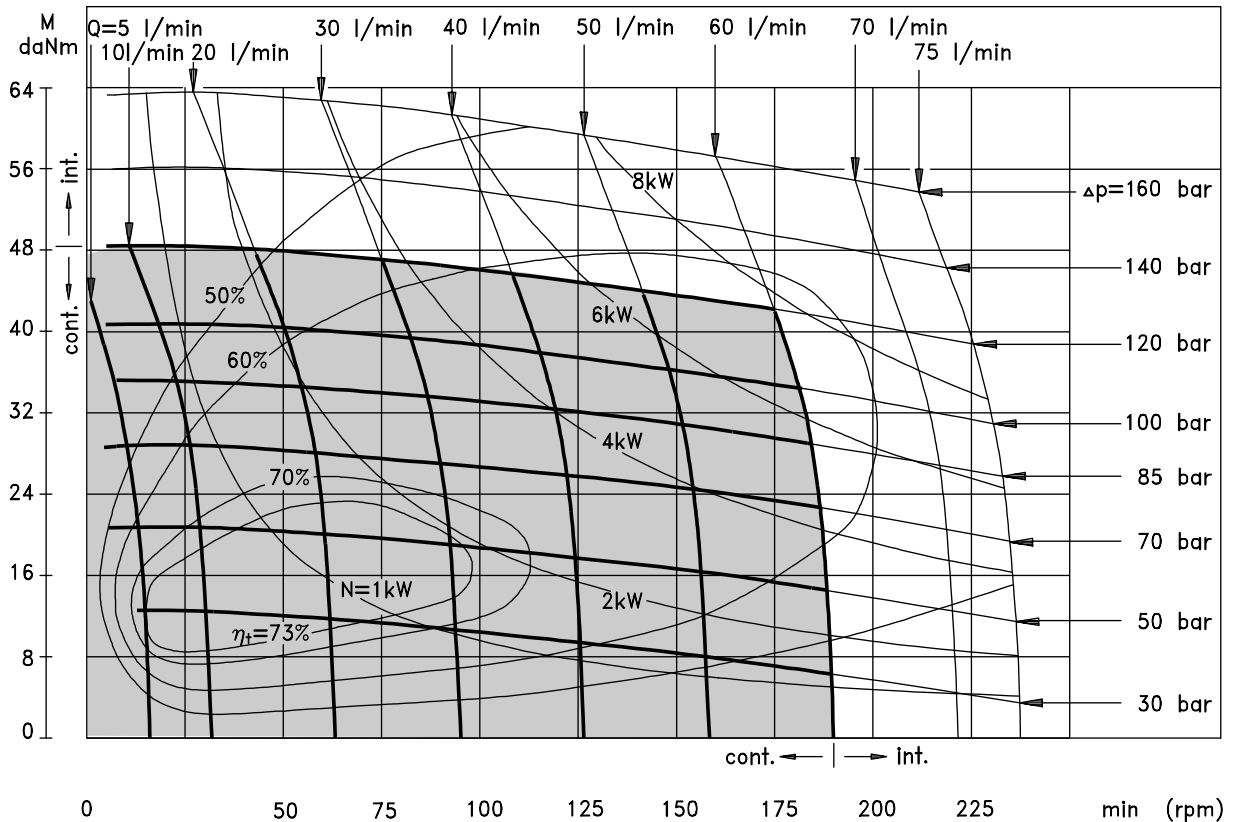

The function diagrams data was collected at back pressure 5÷10 bar and oil with viscosity of 32 mm²/s at 50° C.

FUNCTION DIAGRAM

PL 400

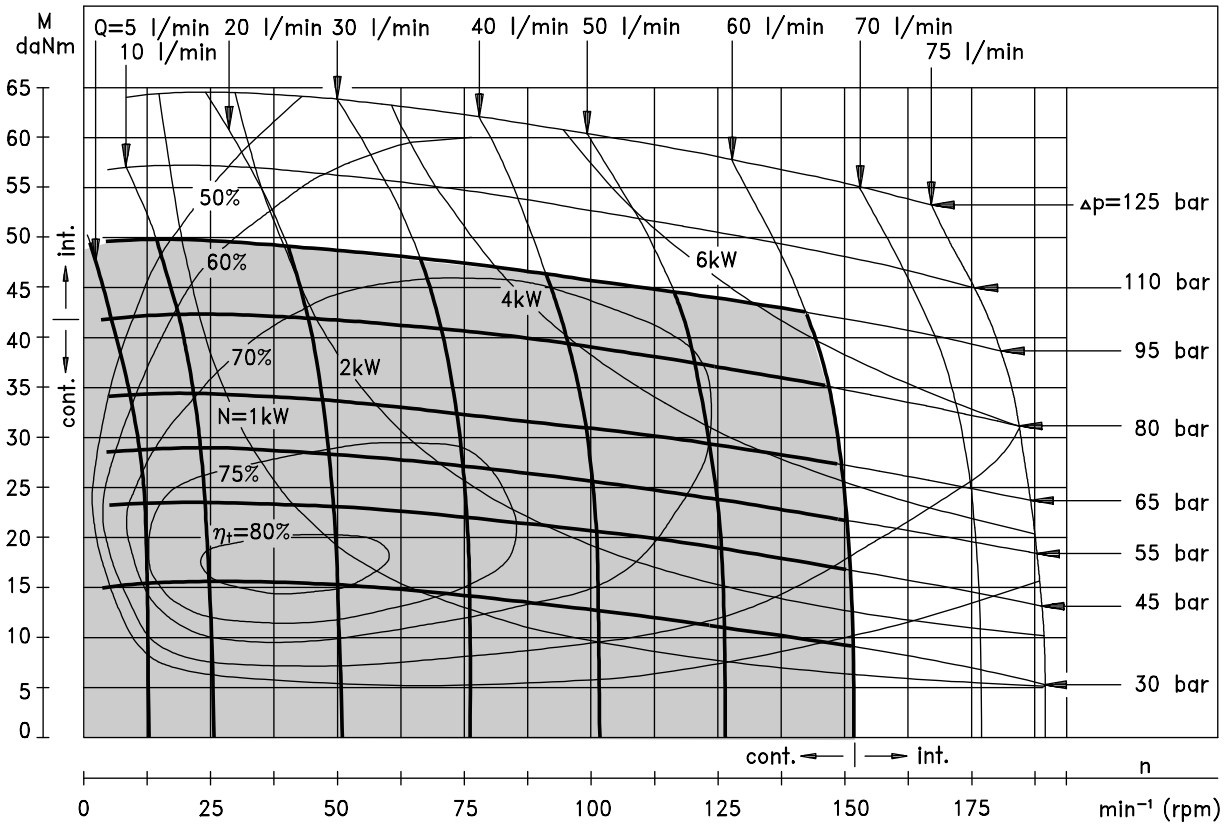

The function diagram data was collected at back pressure 5÷10 bar and oil with viscosity of 32 mm²/s at 50° C.

Permissible Shaft Loads PL

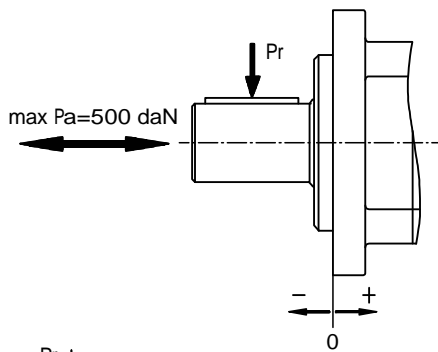

- A- Static load
- B- $Pa = 200 \text{ daN}$
- C- $Pa = 500 \text{ daN}$

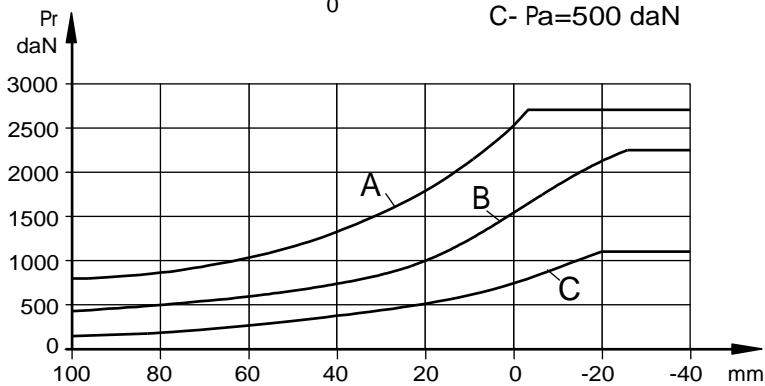

DIMENSIONS AND MOUNTING DATA

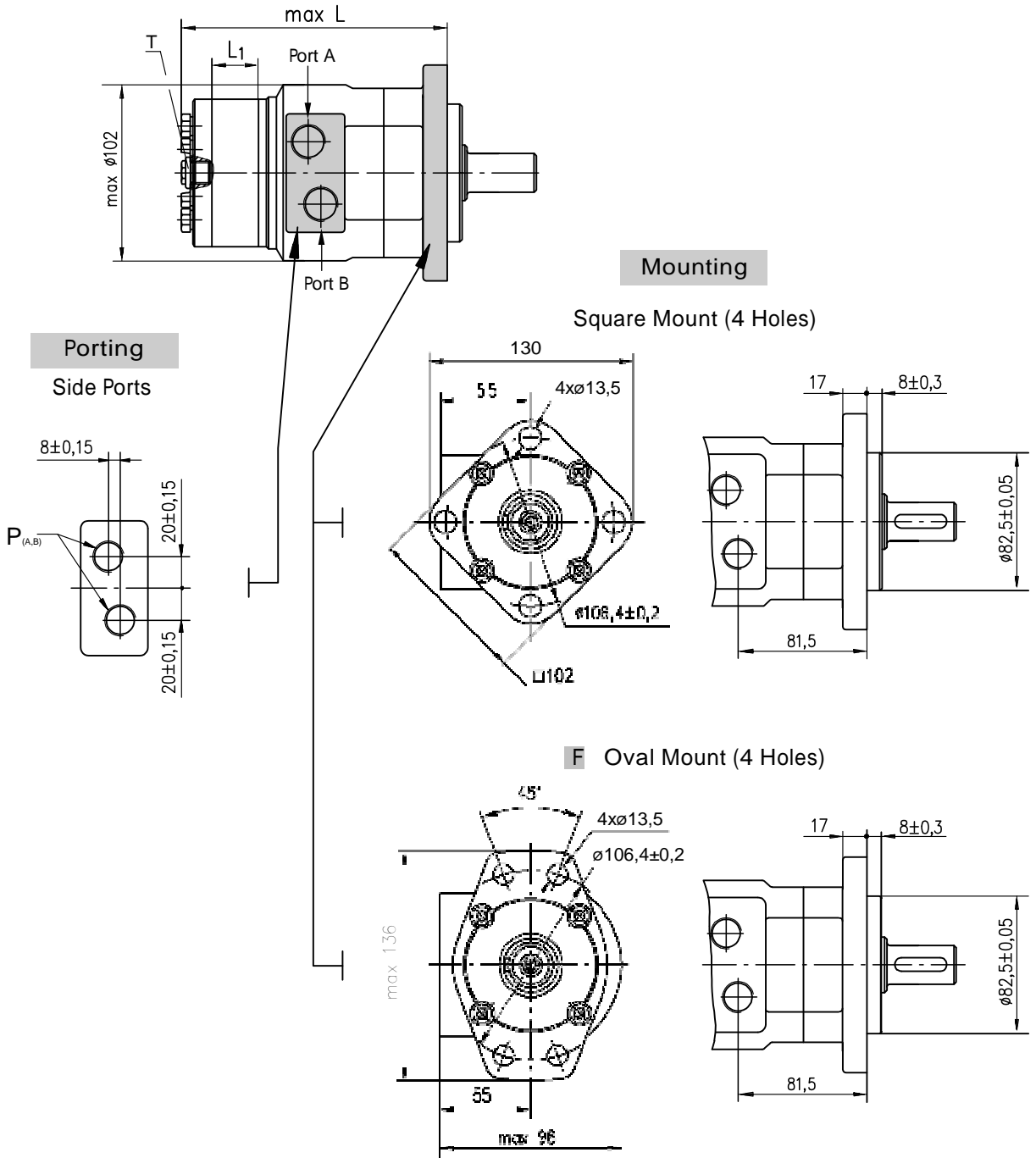

Type	L, mm	L1, mm
PL 50	148	6,67
PL 80	152	10,67
PL 100	155	13,33
PL 125	158	16,67
PL 160	163	21,33
PL 200	168	26,67
PL 250	175	33,33
PL 315	184	42,67
PL 400	195	53,33

P_(A, B): 2xG1/2 or 2xM22x1,5 - 15 mm depth
 T : G1/4 or M14x1,5 - 12 mm depth (plugged)

Standard Rotation	Reverse Rotation
Viewed from Shaft End	Viewed from Shaft End
Port A Pressurized - CW	Port A Pressurized - CCW
Port B Pressurized - CCW	Port B Pressurized - CW

SHAFT EXTENSIONS

C - $\varnothing 25$ straight, Parallel key A8x7x30 DIN 6885
Max. Torque 34 daNm

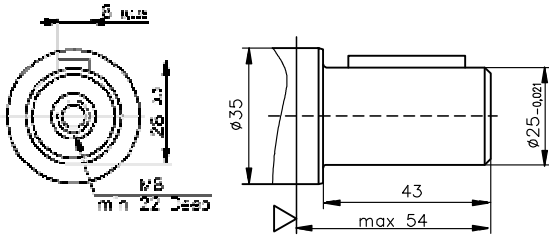

SA - splined B25x22 DIN 5482
Max. Torque 40 daNm

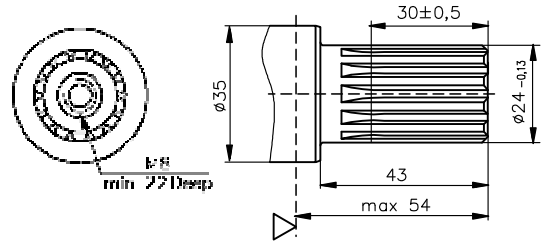

CO - $\varnothing 1$ " straight, Parallel key $\frac{1}{4}$ "x $\frac{1}{4}$ "x $\frac{1}{4}$ " BS46
Max. Torque 34 daNm

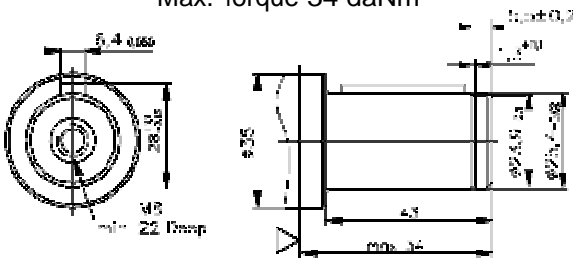

CB - $\varnothing 32$ straight, Parallel key A10x8x40 DIN 6885
Max. Torque 77 daNm

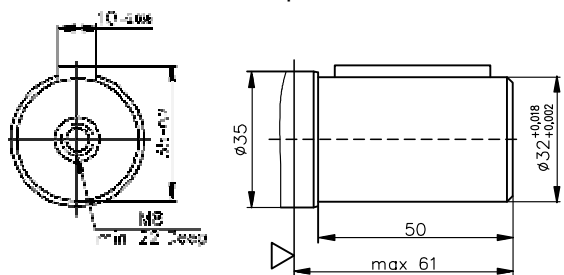

SH - splined, BS 2059 (SAE 6B)
Max. Torque 40 daNm

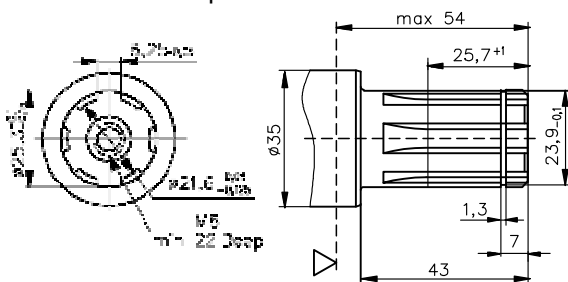

HB - $\varnothing 1\frac{1}{4}$ " splined 14T, DP12/24 ANSI B92.1-1976
Max. Torque 95 daNm

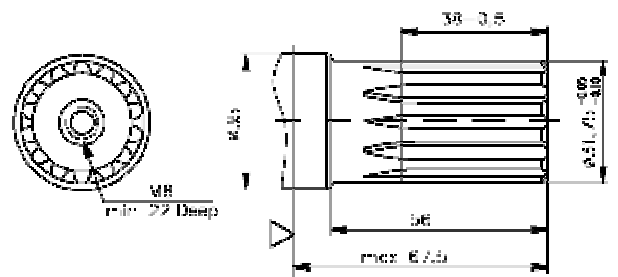

KB - tapered 1:10, Woodruff key 6x9 DIN6888
Max. Torque 95 daNm

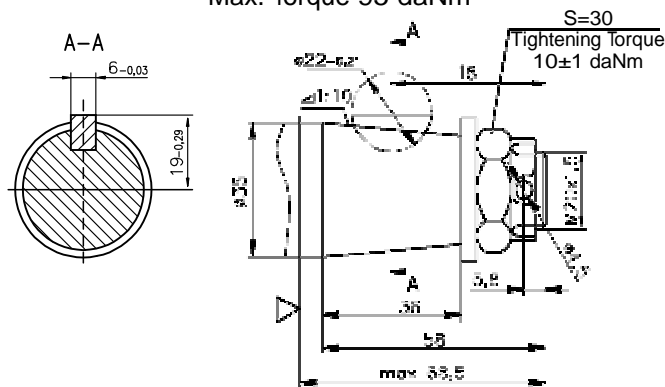

▽ _ Motor Mounting Surface



ORDER CODE

	1	2	3	4	5	6
PL						

Pos.1 - Mounting Flange

omit - Square mount, four holes

F - Oval mount, four holes

Pos.2 - Displacement code

<input type="checkbox"/> 50	- 49,5 [cm ³ /rev]
<input type="checkbox"/> 80	- 79,2 [cm ³ /rev]
<input type="checkbox"/> 100	- 99,0 [cm ³ /rev]
<input type="checkbox"/> 125	- 123,8 [cm ³ /rev]
<input type="checkbox"/> 160	- 158,4 [cm ³ /rev]
<input type="checkbox"/> 200	- 198,0 [cm ³ /rev]
<input type="checkbox"/> 250	- 247,5 [cm ³ /rev]
<input type="checkbox"/> 315	- 316,8 [cm ³ /rev]
<input type="checkbox"/> 400	- 396,0 [cm ³ /rev]

Pos.3 - Shaft extensions*

<input type="checkbox"/> C	- ø25 straight, Parallel key A8x7x30 DIN6885
<input type="checkbox"/> CO	- ø1" straight, Parallel key ¼"x¼"x1¼" BS46
<input type="checkbox"/> SH	- ø25,3 splined BS 2059 (SAE 6B)
<input type="checkbox"/> SA	- ø24 splined B 25x22 DIN 5482
<input type="checkbox"/> CB	- ø32 straight, Parallel key A10x8x40 DIN6885
<input type="checkbox"/> HB	- ø1¼" splined 14T ANSI B92.1 - 1976
<input type="checkbox"/> KB	- ø35 tapered 1:10, Woodruff key 6x9 DIN6888

Pos. 4 - Ports

omit - BSPP (ISO 228)

M - Metric (ISO 262)

Pos. 5 - Special Features ([see page 53](#))

Pos. 6 - Design Series

omit - Factory specified

NOTES:

* The permissible output torque for shafts must not be exceeded!

The hydraulic motors are mangano-phosphatized as standard.

ООО «Кама-Флекс-Гидравлика» (8552) 44-33-58

<http://www.oookfg.narod.ru>

e-mail: kama-hydraulic@narod.ru