

# HYDRAULIC MOTORS MS

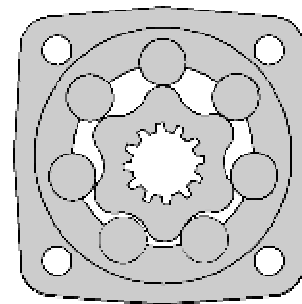

## APPLICATION

- » Conveyors
- » Metal working machine
- » Machines for agriculture
- » Road building machines
- » Mining machinery
- » Food industries
- » Special vehicles etc.



## CONTENTS

Specification data .....	5÷6
Function diagrams .....	7÷10
Dimensions and mounting .....	11÷12
Wheel motor .....	13
Motor with Drum brake- MSB .....	14
Shaft extensions .....	15
Permissible shaft loads .....	16
Function diagram for MSB .....	16
Permissible Shaft Seal pressure.....	17
Tacho connection .....	17
Dimensions and mounting- MSS, V, U .....	18÷20
Internal Spline data .....	20
Order code .....	21

## OPTIONS

- » Model- Disc valve, roll-gerotor
- » Flange and wheel mount
- » Short motor
- » Motor with Drum Brake
- » Tacho connection
- » Speed sensing
- » Side and rear ports
- » Shafts- straight, splined and tapered
- » Metric and BSPP ports
- » Other special features

## GENERAL

Displacement, [cm <sup>3</sup> /rev.]	80,5÷397
Max. Speed, [RPM]	190÷810
Max. Torque, [daNm]	20÷58
Max. Output, [kW]	20÷10
Max. Pressure Drop, [bar]	100÷200
Max. Oil Flow, [l/min]	75
Min. Speed, [RPM]	5÷10
Permissible Shaft Loads, [daN]	P <sub>a</sub> =500
Pressure fluid	Mineral based- HLP(DIN 51524) or HM(ISO 6743/4)
Temperature range, [°C]	-30÷90
Optimal Viscosity range, [mm <sup>2</sup> /s]	20÷75
Filtration	ISO code 20/16 (Min. recommended fluid filtration of 25 micron)

Oil flow in drain line

Pressure drop (bar)	Viscosity (mm <sup>2</sup> /s)	Oil flow in drain line (l/min)
140	20	1,5
	35	1
210	20	3
	35	2

Pressure Losses

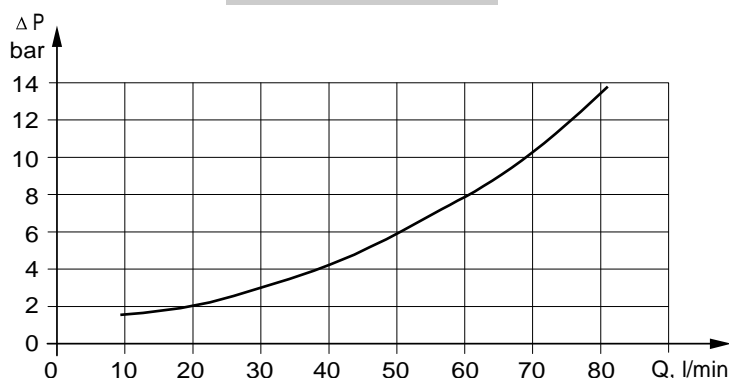

## SPECIFICATION DATA

Type		MS 80	MS 100	MS 125	MS 160
Displacement [cm <sup>3</sup> /rev.]		80,5	100	125,7	159,7
Max. Speed, [RPM]	cont.	810	750	600	470
	Int.*	1000	900	720	560
Max. Torque [daNm]	cont.	20	29,2	37,4	46
	Int.*	24	32	41	51,5
	peak**	26	32	41	51,5
Max. Output [kW]	cont.	16,4	19,5	20	15,5
	int.*	22	26	24	21,9
Max. Pressure Drop [bar]	cont.	175	205	205	205
	Int.*	210	225	225	225
	peak**	225	225	225	225
Max. Oil Flow [l/min]	cont.	65	75	75	75
	Int.*	80	90	90	90
Max. Inlet Pressure [bar]	cont.	210	210	210	210
	Int.*	250	250	250	250
	peak**	300	300	300	300
Max. Return Pressure with Drain Line [bar]	cont.	140	140	140	140
	Int.*	175	175	175	175
	peak**	210	210	210	210
Max. Starting Pressure with Unloaded Shaft, [bar]		12	10	10	8
Min. Starting Torque [daNm]	at max. press. drop cont.	16,5	23,9	26	36,9
	at max. press. drop Int.*	19,4	26,4	31	40,5
Min. Speed***, [RPM]		10	10	8	8
Weight, [kg]  For Rear Ports +0,4 kg	MS(F)	9,9	10,1	10,4	10,8
	MSW	10,4	10,6	10,9	11,3
	MSS(Z)	7,9	8,1	8,4	8,8
	MSV	5,8	6	6,3	6,7
	MSQ	10,3	10,5	10,8	11,2
	MSB	16,9	17,1	17,4	17,8

\* Intermittent operation: the permissible values may occur for max. 10% of every minute.

\*\* Peak load: the permissible values may occur for max. 1% of every minute.

\*\*\* For speeds of 5 RPM lower than given, consult factory or your regional manager.

- 1) Intermittent speed and intermittent pressure must not occur simultaneously.
- 2) Recommended filtration is per ISO cleanliness code 20/16. A nominal filtration of 25 micron or better.
- 3) Recommend using a premium quality, anti-wear type mineral based hydraulic oil HLP(DIN51524) or HM (ISO 6743/4).  
If using synthetic fluids consult the factory for alternative seal materials.
- 4) Recommended minimum oil viscosity 13 mm<sup>2</sup>/s at operating temperatures.
- 5) Recommended maximum system operating temperature is 82°C.
- 6) To assure optimum motor life fill with fluid prior to loading and run at moderate load and speed for 10-15 minutes.

**SPECIFICATION DATA (continued)**

Type		MS 200	MS 250	MS 315	MS 400
Displacement [cm <sup>3</sup> /rev.]		200	250	314,9	397
Max. Speed, [RPM]	cont.	375	300	240	190
	Int.*	450	360	290	230
Max. Torque [daNm]	cont.	46	50	54	58
	Int.*	60	63	63	69
	peak**	65	72	84	85
Max. Output [kW]	cont.	14	13,5	11,5	10
	int.*	21	21	13,5	13
Max. Pressure Drop [bar]	cont.	160	140	120	100
	Int.*	210	175	140	120
	peak**	225	200	185	140
Max. Oil Flow [l/min]	cont.	75	75	75	75
	Int.*	90	90	90	90
Max. Inlet Pressure [bar]	cont.	210	210	210	210
	Int.*	250	250	250	250
	peak**	300	300	300	300
Max. Return Pressure with Drain Line [bar]	cont.	140	140	140	140
	Int.*	175	175	175	175
	peak**	210	210	210	210
Max. Starting Pressure with Unloaded Shaft, [bar]		8	8	8	8
Min. Starting Torque [daNm]	at max. press. drop cont.	37,5	40	51	54
	at max. press. drop Int.*	48,5	50	65	63
Min. Speed***, [RPM]		6	6	5	5
Weight, [kg]  For Rear Ports +0,4 kg	MS(F)	11,2	11,7	12,4	13,3
	MSW	11,7	12,2	12,9	13,8
	MSS(Z)	9,2	9,7	10,4	11,3
	MSV	7,1	7,6	8,3	9,2
	MSQ	11,6	12,1	12,8	13,7
	MSB	18,2	18,7	19,4	20,3

\* Intermittent operation: the permissible values may occur for max. 10% of every minute.

\*\* Peak load: the permissible values may occur for max. 1% of every minute.

\*\*\* For speeds of 5 RPM lower than given, consult factory or your regional manager.

- 1) Intermittent speed and intermittent pressure must not occur simultaneously.
- 2) Recommended filtration is per ISO cleanliness code 20/16. A nominal filtration of 25 micron or better.
- 3) Recommend using a premium quality, anti-wear type mineral based hydraulic oil HLP(DIN51524) or HM (ISO 6743/4).  
If using synthetic fluids consult the factory for alternative seal materials.
- 4) Recommended minimum oil viscosity 13 mm<sup>2</sup>/s at operating temperatures.
- 5) Recommended maximum system operating temperature is 82°C.
- 6) To assure optimum motor life fill with fluid prior to loading and run at moderate load and speed for 10-15 minutes.

**FUNCTION DIAGRAMS**

**MS 80**

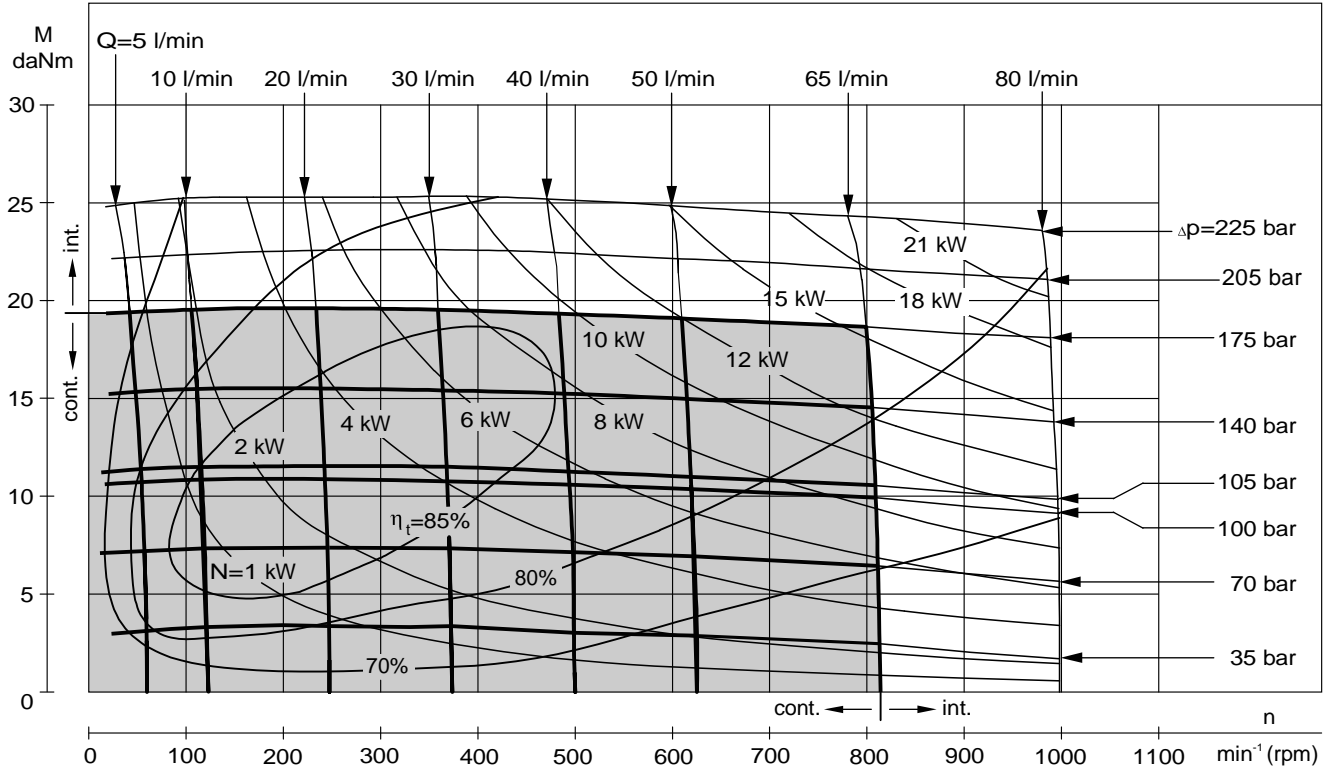

**MS 100**

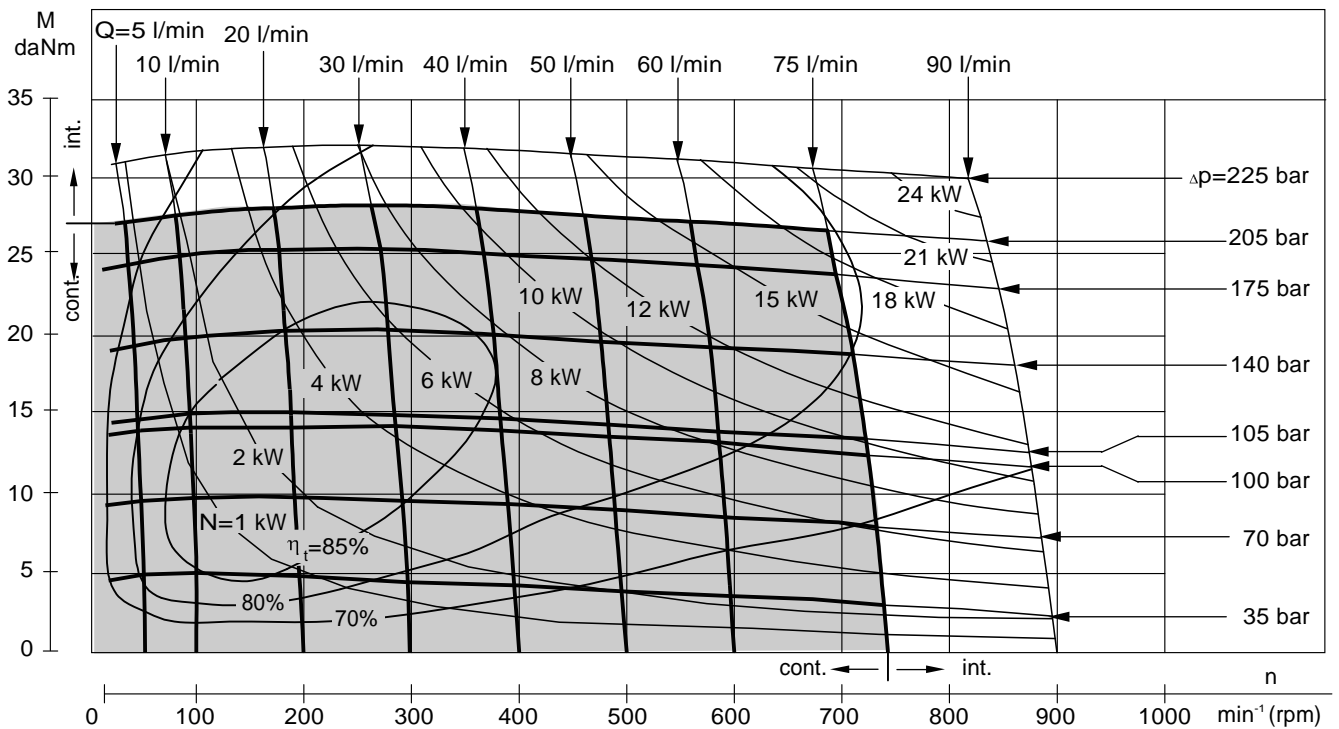

The function diagrams data was collected at back pressure 5÷10 bar and oil with viscosity of 32 mm<sup>2</sup>/s at 50° C.

**FUNCTION DIAGRAMS**

**MS 125**

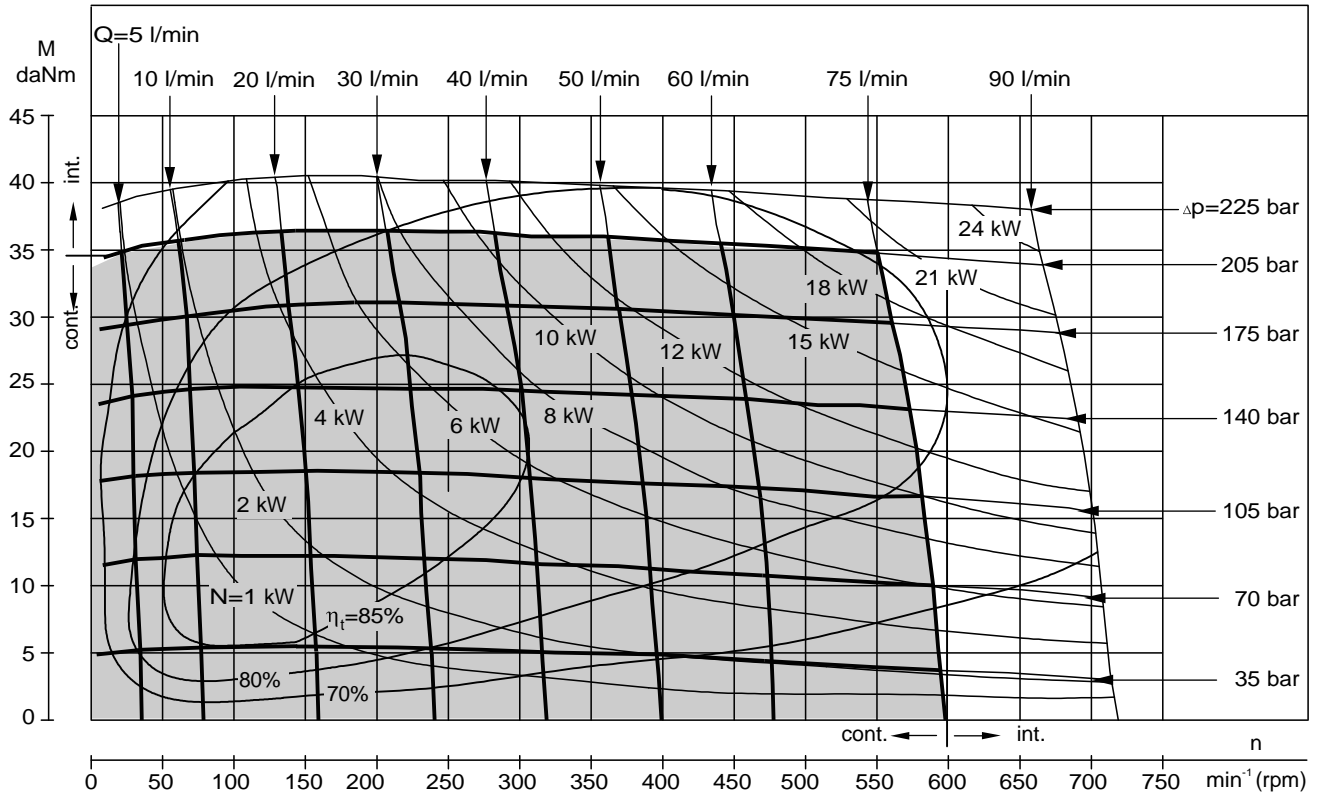

**MS 160**

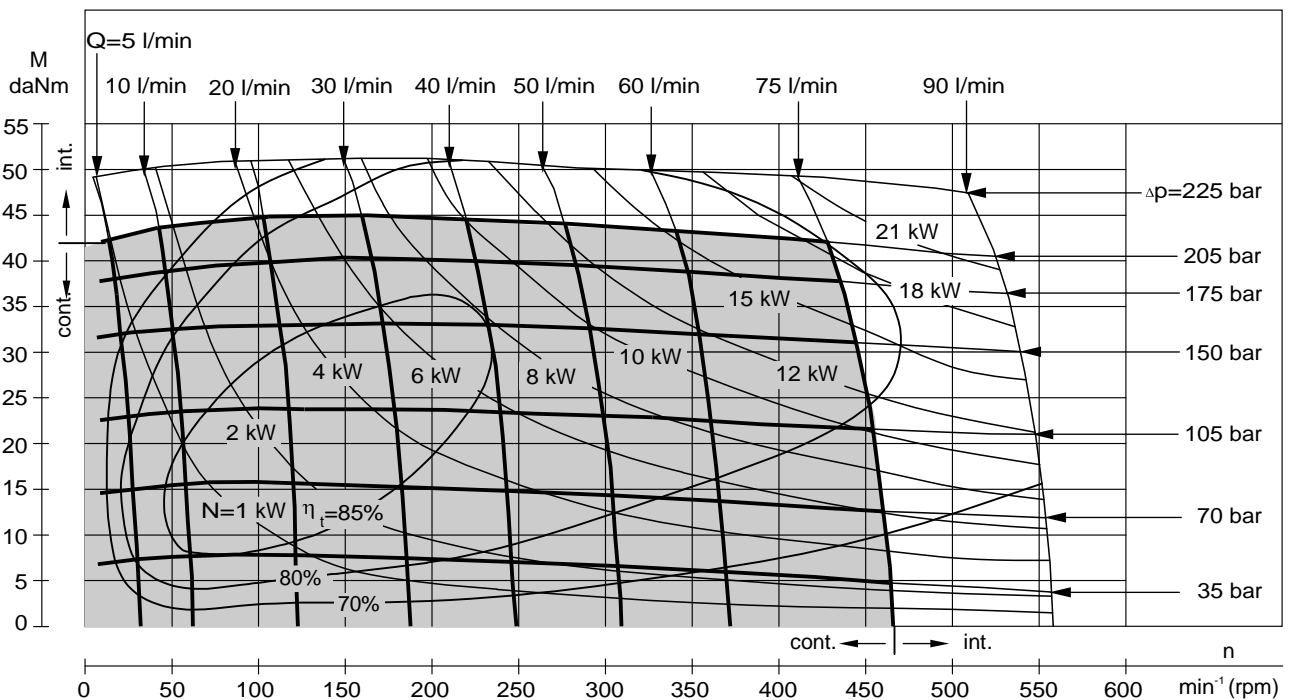

The function diagrams data was collected at back pressure 5÷10 bar and oil with viscosity of 32  $\text{mm}^2/\text{s}$  at 50° C.

**FUNCTION DIAGRAMS**

**MS 200**

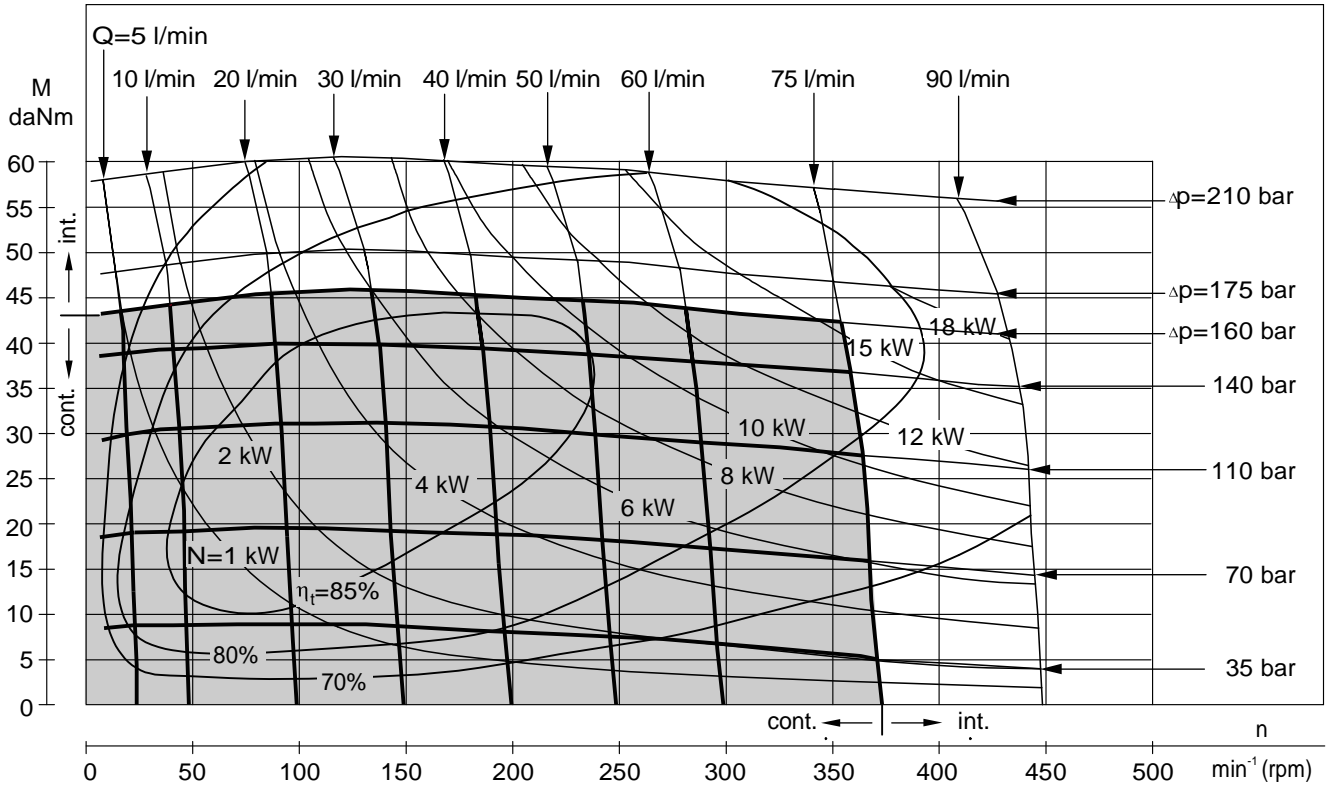

**MS 250**

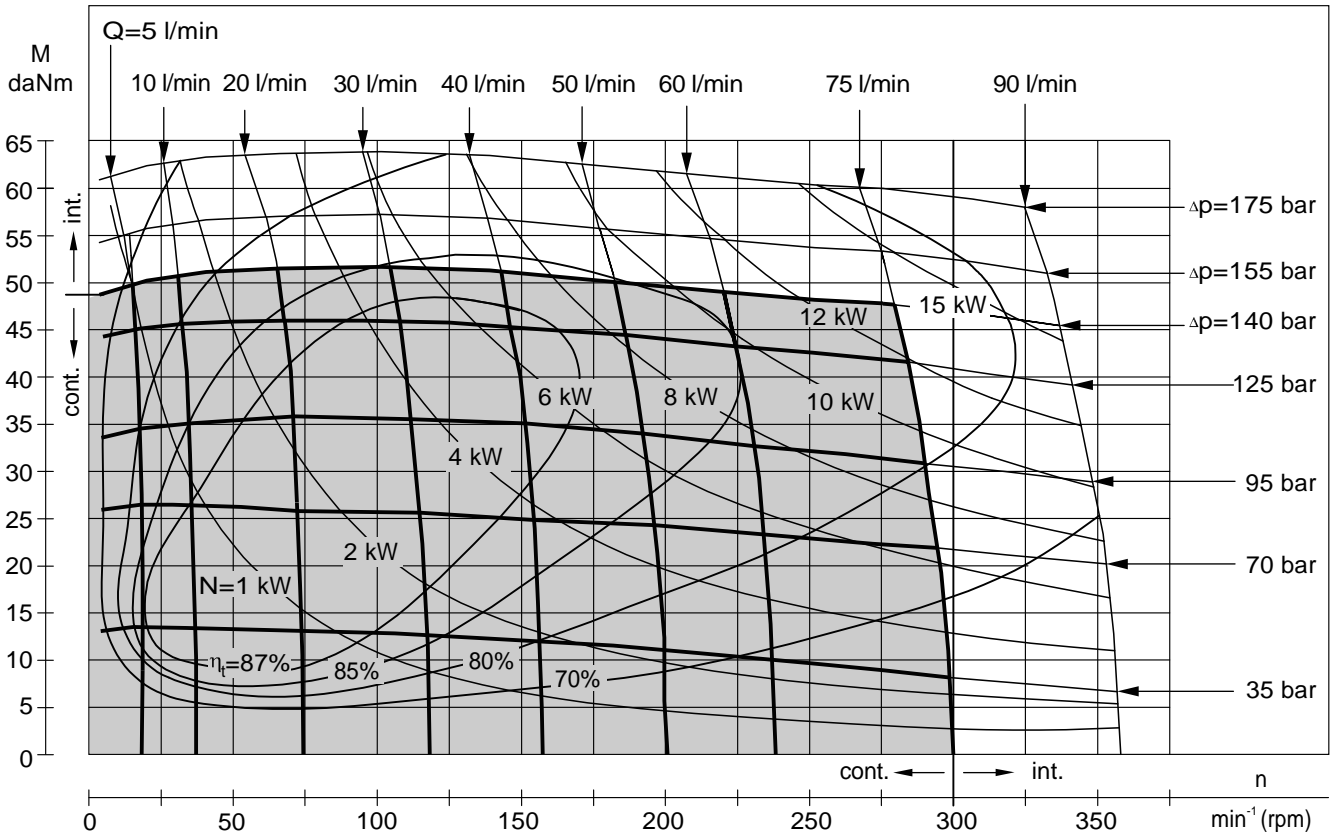

The function diagrams data was collected at back pressure 5÷10 bar and oil with viscosity of 32 mm<sup>2</sup>/s at 50° C.

**MS 315**

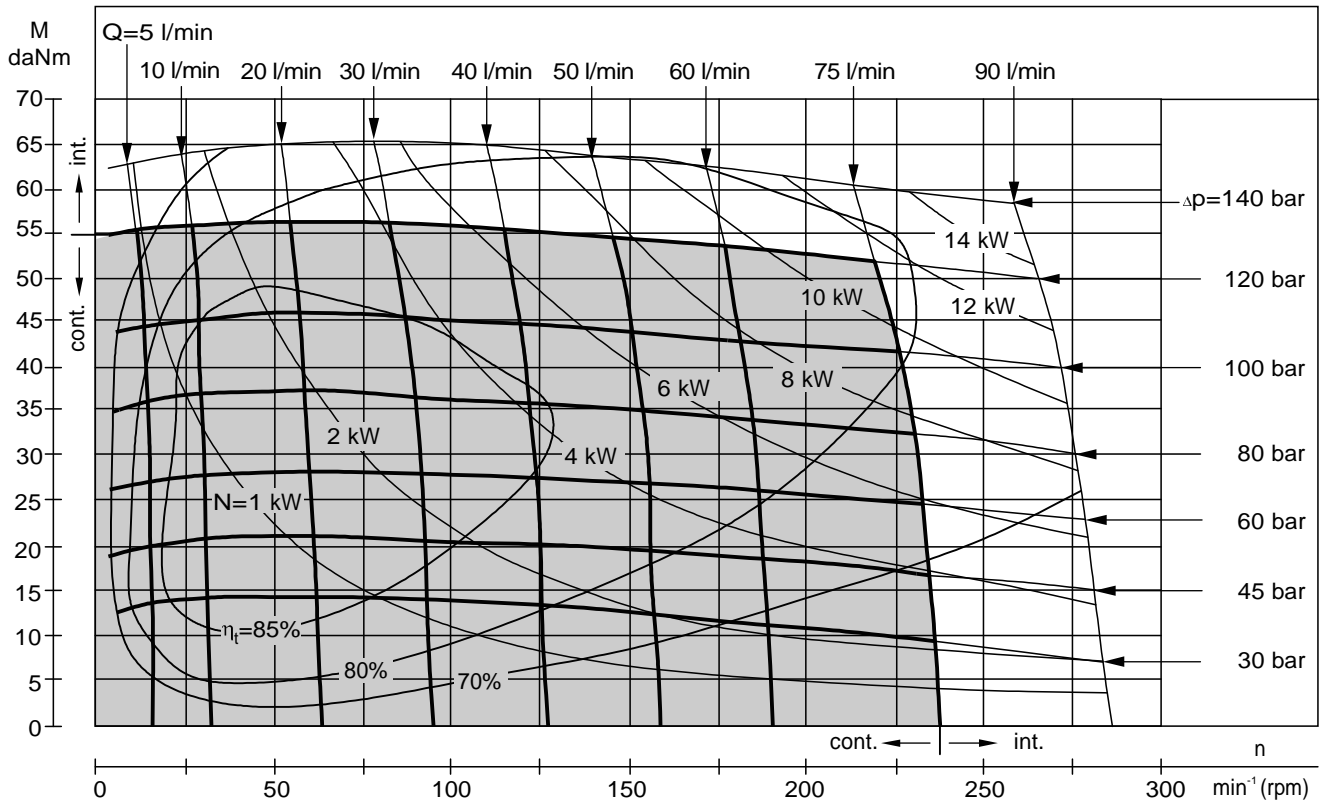

**MS 400**

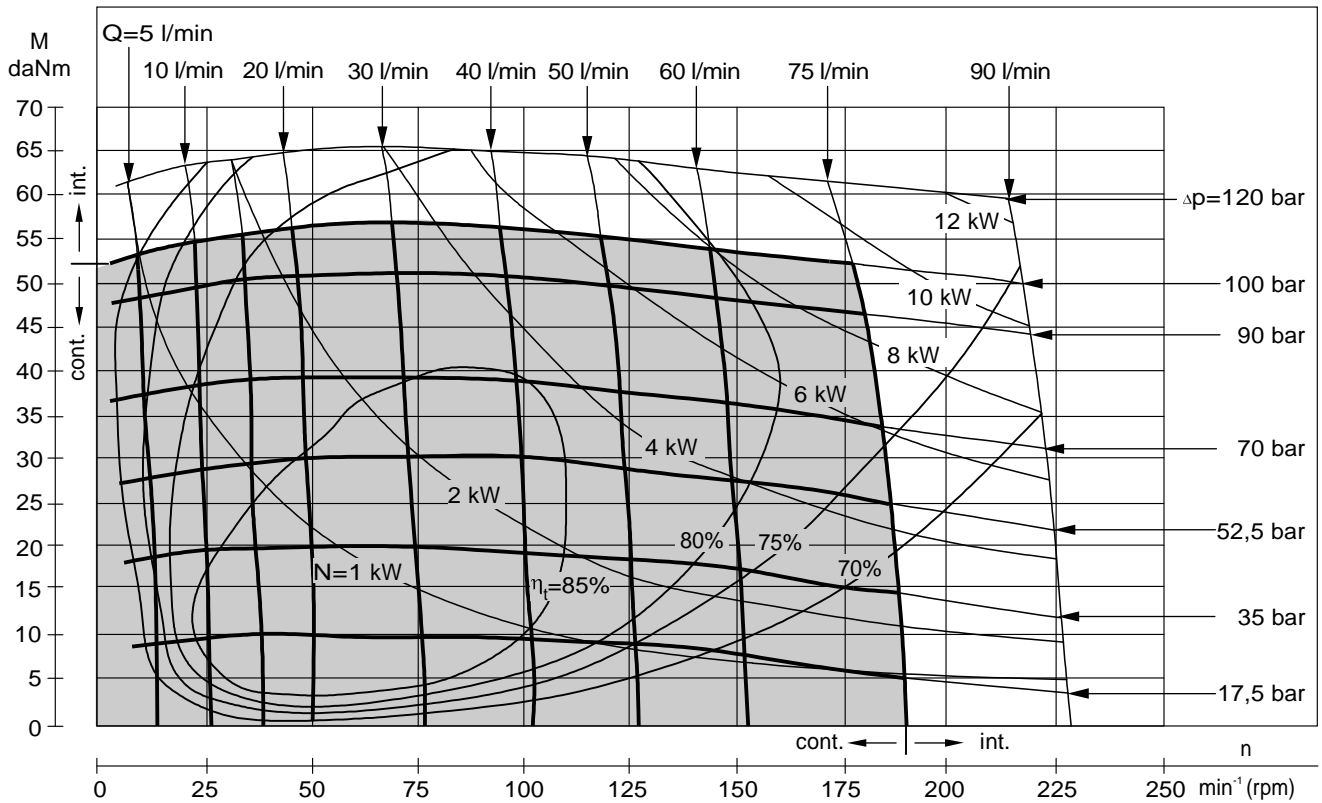

The function diagrams data was collected at back pressure  $5 \div 10$  bar and oil with viscosity of  $32 \text{ mm}^2/\text{s}$  at  $50^\circ \text{C}$ .

**DIMENSIONS AND MOUNTING DATA**

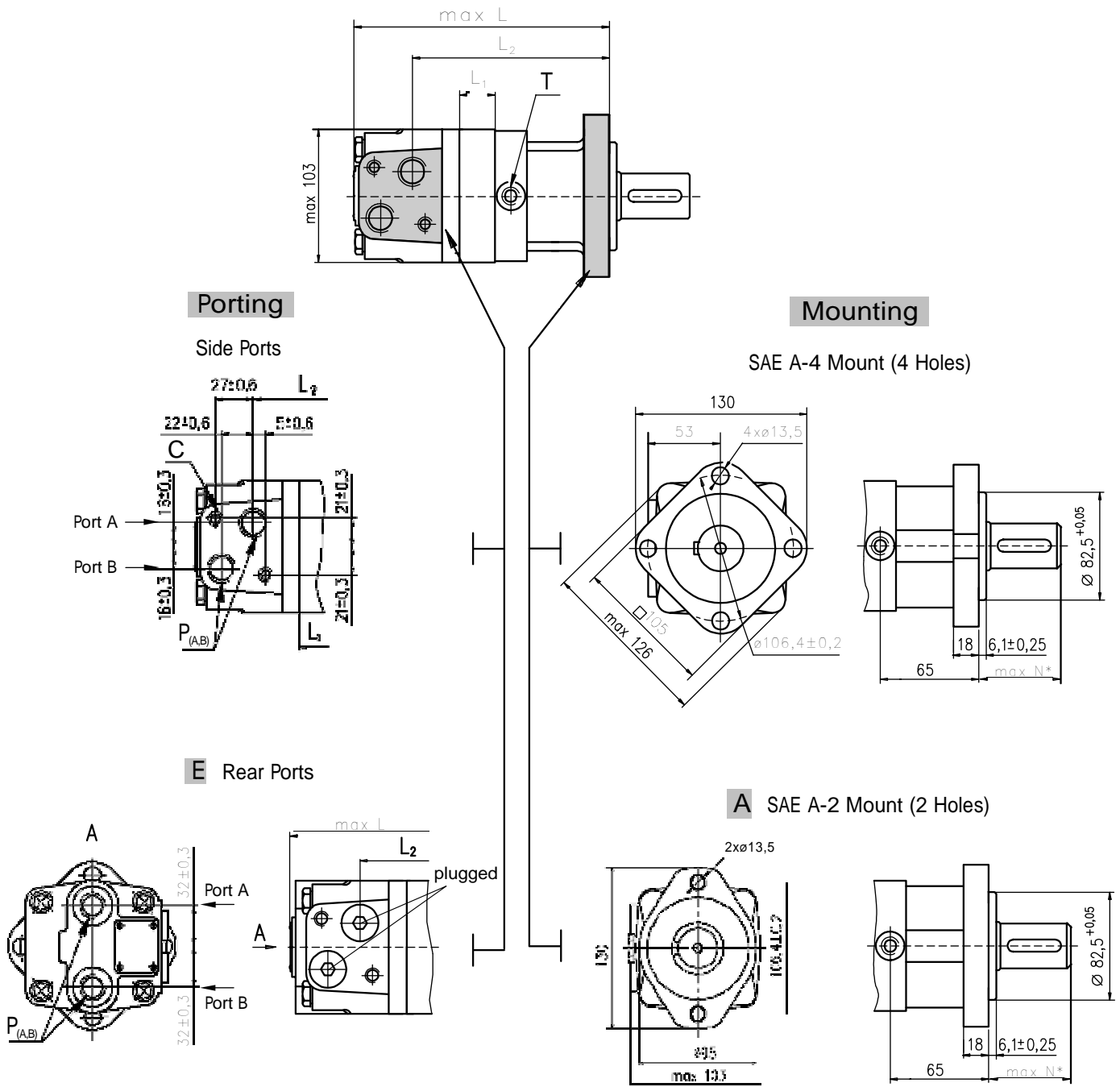

\*For N see page 15

C: 2xM10-12 mm depth  
 P<sub>(A,B)</sub>: 2xG1/2 or 2xM22x1,5-15 mm depth  
 T: G ¼ or M14x1,5- 12 mm depth (plugged)

Standard Rotation  
 Viewed from Shaft End  
 Port A Pressurized - CW  
 Port B Pressurized - CCW

Reverse Rotation  
 Viewed from Shaft End  
 Port A Pressurized - CCW  
 Port B Pressurized - CW

Type	L, mm	L <sub>2</sub> , mm	Type	L, mm	L <sub>1</sub> , mm
MS(A) 80	168	124	MS(A)E 80	173	14
MS(A) 100	171	129	MS(A)E 100	177	17,4
MS(A) 125	176	132	MS(A)E 125	181	21,8
MS(A) 160	182	138	MS(A)E 160	187	27,8
MS(A) 200	189	145	MS(A)E 200	194	34,8
MS(A) 250	197	154	MS(A)E 250	203	43,5
MS(A) 315	209	165	MS(A)E 315	214	54,8
MS(A) 400	223	179	MS(A)E 400	228	69,4
MSY(A) 475	237	193	MSY(A)E 475	242	82,6



**DIMENSIONS AND MOUNTING DATA**

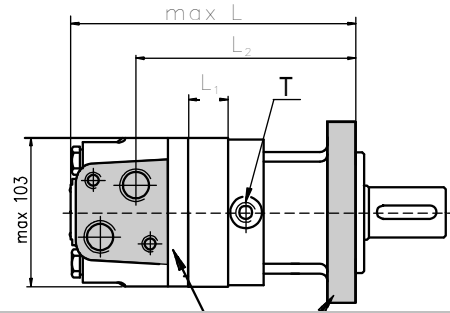

**Porting**

**Mounting**

**Side Ports**

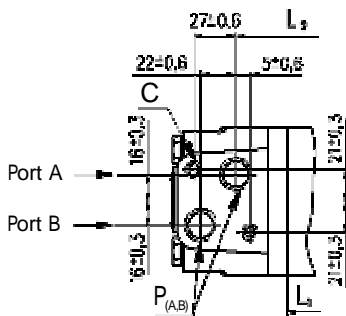

**F Magneto Mount (4 Holes)**

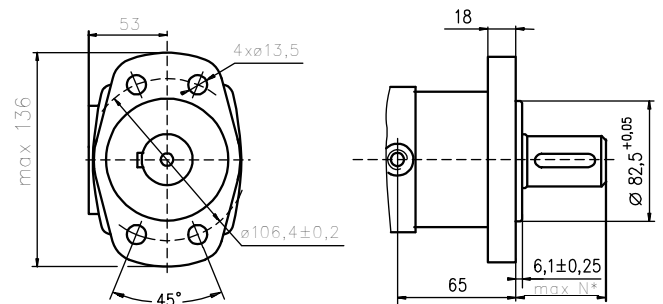

**E Rear Ports**

**Q Square Mount (4 Holes)**

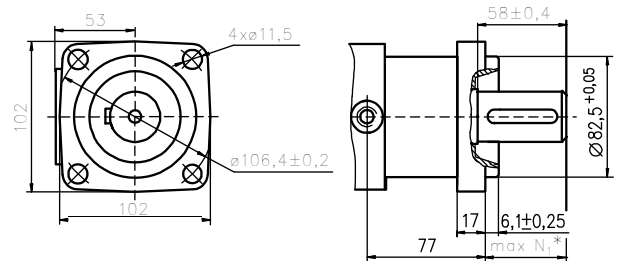
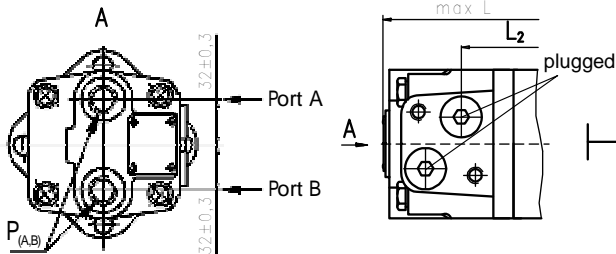

\*For N and N<sub>1</sub> see page 15

C: 2xM10-12 mm depth  
P<sub>(A,B)</sub>: 2xG1/2 or 2xM22x1,5-15 mm depth  
T: G ¼ or M14x1,5- 12 mm depth (plugged)

Standard Rotation  
Viewed from Shaft End  
Port A Pressurized - CW  
Port B Pressurized - CCW

Reverse Rotation  
Viewed from Shaft End  
Port A Pressurized - CCW  
Port B Pressurized - CW

Type	L, mm	L <sub>2</sub> , mm	Type	L, mm	L <sub>2</sub> , mm	Type	L, mm	Type	L, mm	L <sub>1</sub> , mm
MSF 80	168	124	MSQ 80	179	136	MSFE 80	173	MSQE 80	185	14
MSF 100	171	129	MSQ 100	183	140	MSFE 100	177	MSQE 100	189	17,4
MSF 125	176	132	MSQ 125	187	144	MSFE 125	181	MSQE 125	193	21,8
MSF 160	182	138	MSQ 160	193	150	MSFE 160	187	MSQE 160	199	27,8
MSF 200	189	145	MSQ 200	200	157	MSFE 200	194	MSQE 200	206	34,8
MSF 250	197	154	MSQ 250	209	166	MSFE 250	203	MSQE 250	215	43,5
MSF 315	209	165	MSQ 315	220	177	MSFE 315	214	MSQE 315	226	54,8
MSF 400	223	179	MSQ 400	235	192	MSFE 400	228	MSQE 400	241	69,4
MSYF 475	237	193	MSYQ 475	247	205	MSYFE 475	242	MSYQE 475	254	82,6

**DIMENSIONS AND MOUNTING DATA -MSW**

**W Wheel Mount**

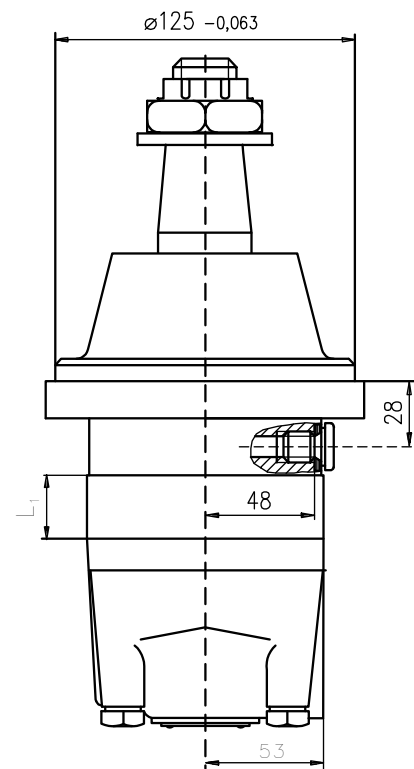
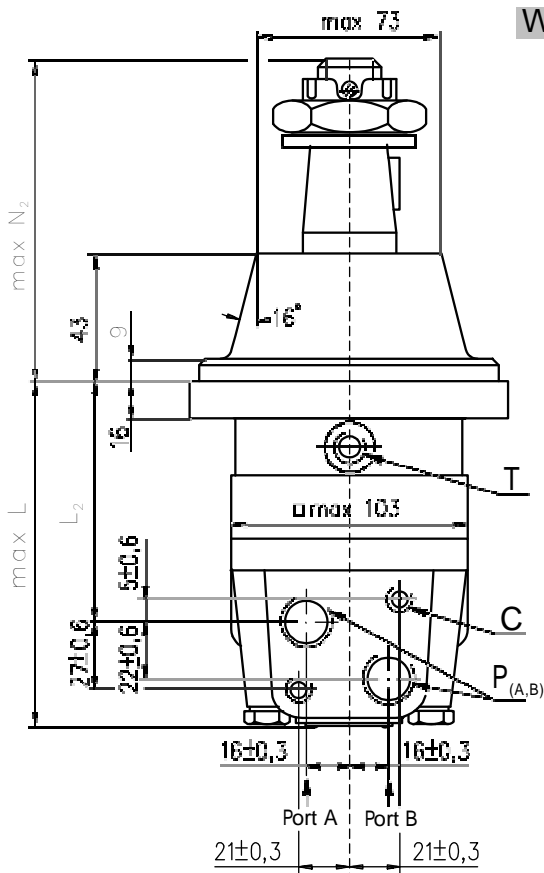

C: 2xM10-12 mm depth  
 P<sub>(A,B)</sub>: 2xG1/2 or 2xM22x1,5-15 mm depth  
 T: G ¼ or M14x1,5 - 12 mm depth(plugged)

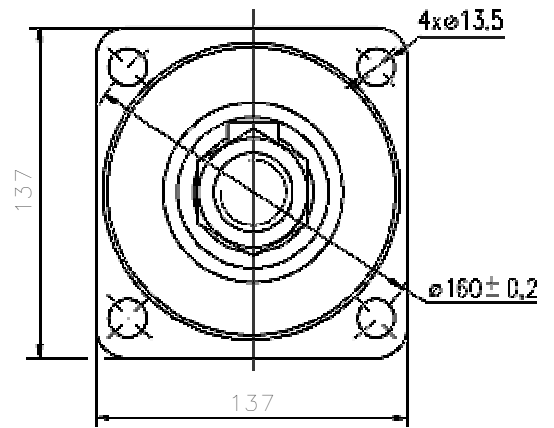

\*For N<sub>2</sub> see page 15

**E Rear Port**

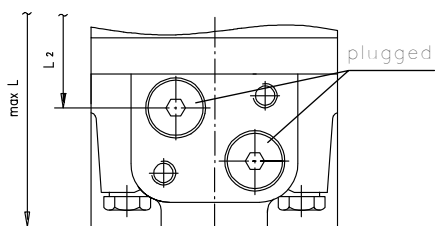
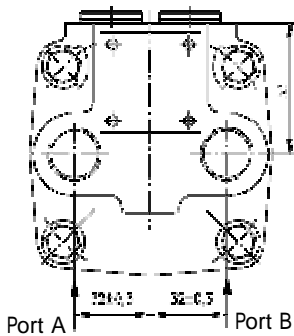

**Standard Rotation**  
 Viewed from Shaft End  
 Port A Pressurized - CW  
 Port B Pressurized - CCW

**Reverse Rotation**  
 Viewed from Shaft End  
 Port A Pressurized - CCW  
 Port B Pressurized - CW

Type	L, mm	L <sub>1</sub> , mm	L <sub>2</sub> , mm	Type	L, mm
MSW 80	129	14	87	MSWE 80	138
MSW100	133	17,4	91	MSWE 100	142
MSW 125	137	21,8	95	MSWE 125	146
MSW 160	143	27,8	101	MSWE 160	152
MSW 200	150	34,8	108	MSWE 200	159
MSW 250	159	43,5	117	MSWE 250	168
MSW 315	170	54,8	128	MSWE 315	179
MSW 400	184	69,4	143	MSWE 400	194
MSYW 475	198	82,6	156	MSYWE 475	207

**B Motor with Drum Brake**

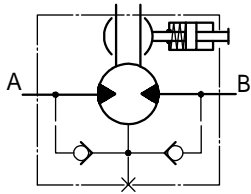

Actuating the brake level, the brake shaft is turned. The rectangular shape of the inner part of this shaft forces the brake pads to be pressed against the brake drum. This brakes the wheel or the winch drum.

Releasing the level, the springs pull it and the brake pads back to the initial position. The motor output shaft is released. Minimum angle adjustment is 10°. It can be adjusted by dismounting the level. Depending on the application You can choose the actuating direction of the brake level. The rod connection actuating the brake should be capable of moving at last 25 mm from neutral to extreme position.

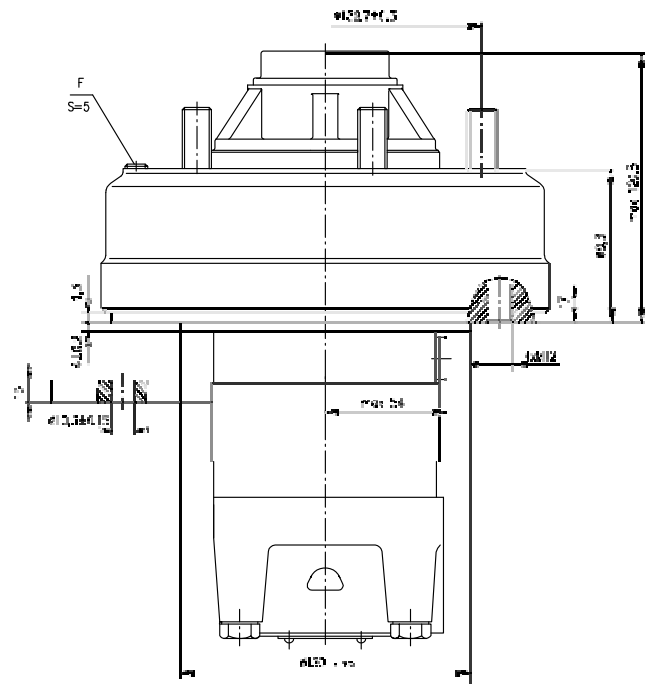
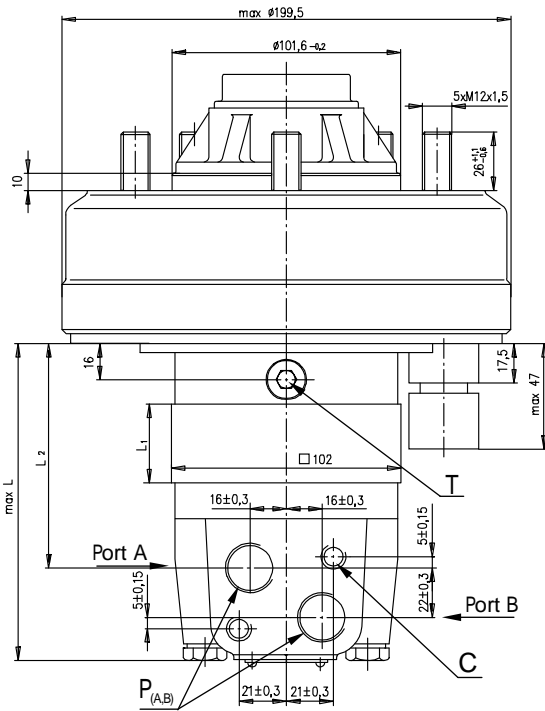
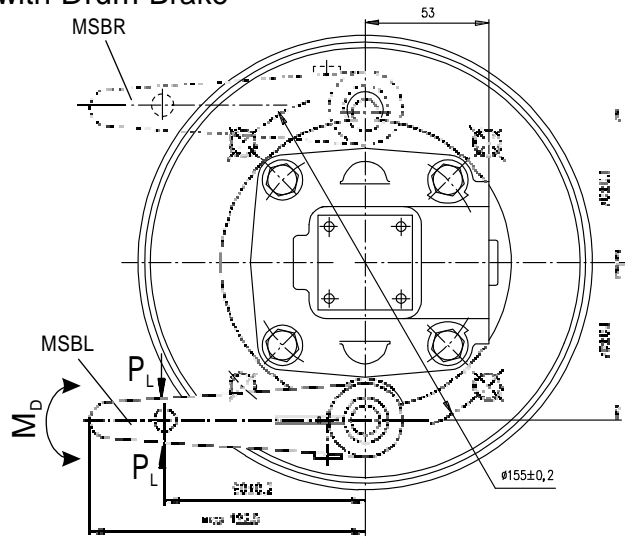

**E Rear Port**

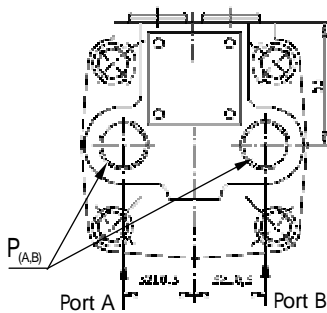

Standard Rotation  
Viewed from Shaft End  
Port A Pressurized - CW  
Port B Pressurized - CCW

Reverse Rotation  
Viewed from Shaft End  
Port A Pressurized - CCW  
Port B Pressurized - CW

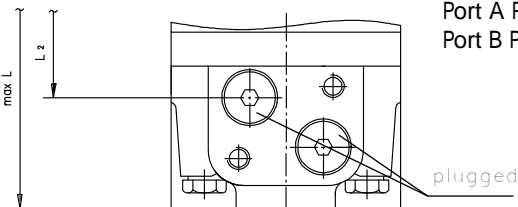

- C: 2xM10-12 mm depth
- F: Inspection hole for checking brake lining
- T: G 1/4 or M14x1,5 - 12 mm depth (plugged)
- P<sub>(A,B)</sub>: 2xG1/2 or 2xM22x1,5-15 mm depth

Type	L, mm	L <sub>1</sub> , mm	L <sub>2</sub> , mm	Type	L, mm
MSB 80	119	14	74	MSBE 80	127
MSB100	122	17,4	77	MSBE 100	130
MSB 125	126	21,8	82	MSBE 125	134
MSB 160	132	27,8	88	MSBE 160	140
MSB 200	139	34,8	95	MSBE 200	147
MSB 250	148	43,5	110	MSBE 250	156
MSB 315	159	54,8	115	MSBE 315	167
MSB 400	174	69,4	130	MSBE 400	182

**SHAFT EXTENSIONS**

**C** -  $\varnothing 32$  straight, Parallel key A10x8x45 DIN 6885  
Max. Torque 77 daNm

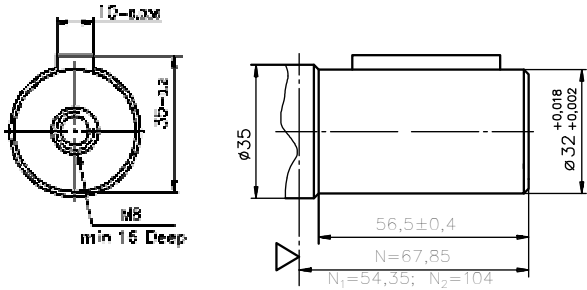

**K** - tapered 1:10, Parallel key B6x6x20 DIN 6885  
Max. Torque 95 daNm

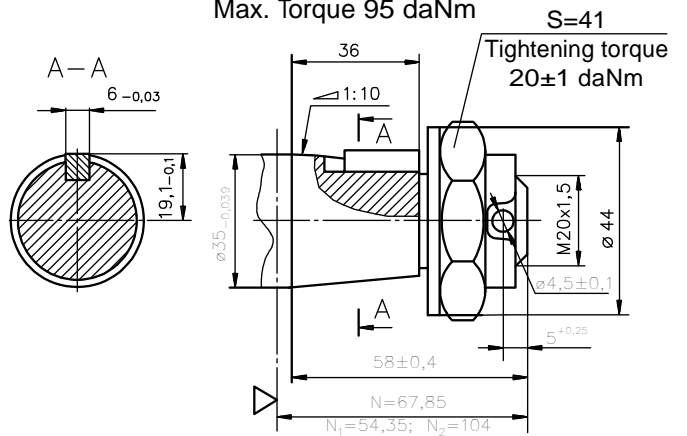

**CO** -  $\varnothing 1\frac{1}{4}$ " straight, Parallel key  $\frac{5}{16}$ " x  $\frac{5}{16}$ " x  $1\frac{1}{4}$ " BS46  
Max. Torque 77 daNm

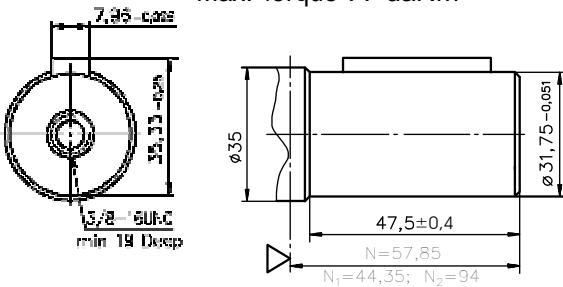

**SH** -  $\varnothing 1\frac{1}{4}$ " splined 14T, DP12/24 ANSI B92.1-1976  
Max. Torque 95 daNm

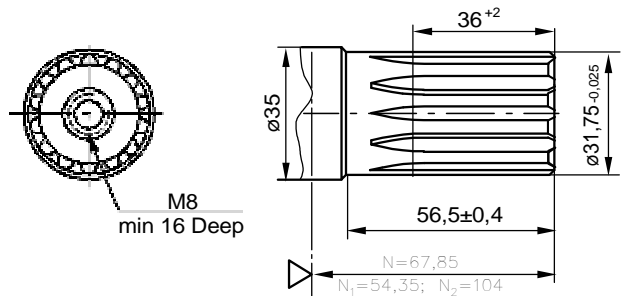

**SL** -  $\varnothing 34,85$  p.t.o. DIN 9611 Form 1  
Max. Torque 77 daNm

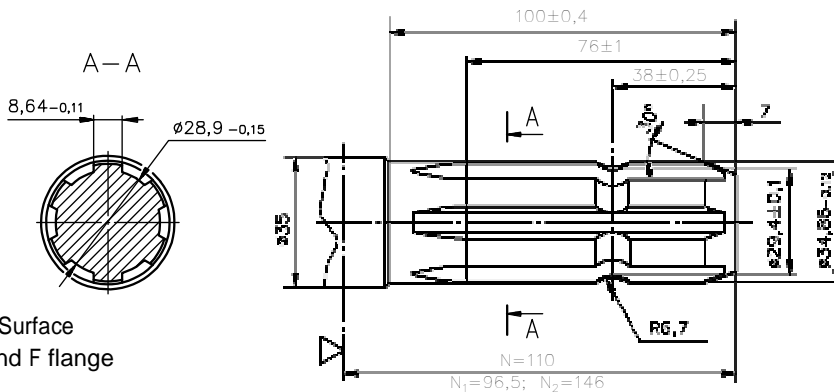

- ▽ - Motor Mounting Surface
- N - for standart, A and F flange
- N<sub>1</sub> - for Q flange
- N<sub>2</sub> - for W flange

**PERMISSIBLE SHAFT LOADS**

The output shaft runs in tapered bearings that permit high axial and radial forces. Curve "1" shows max. radial shaft load. Any shaft load exceeding the values quoted in the curve will seriously reduce motor life. The two other curves apply to a B10 bearing life of 3000 hours at 200 RPM.

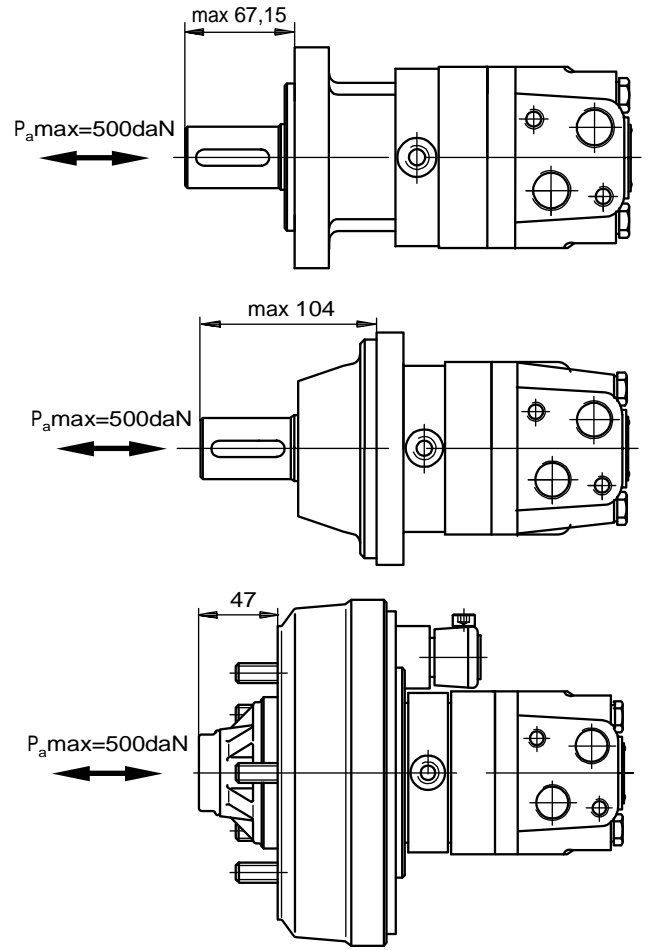
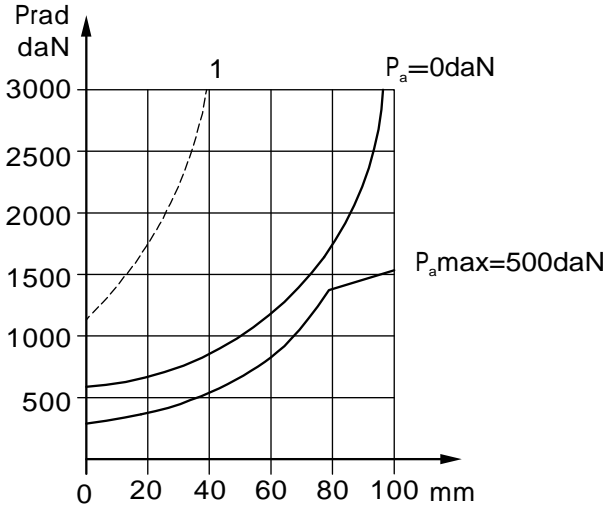

**FUNCTION DIAGRAM MSB**

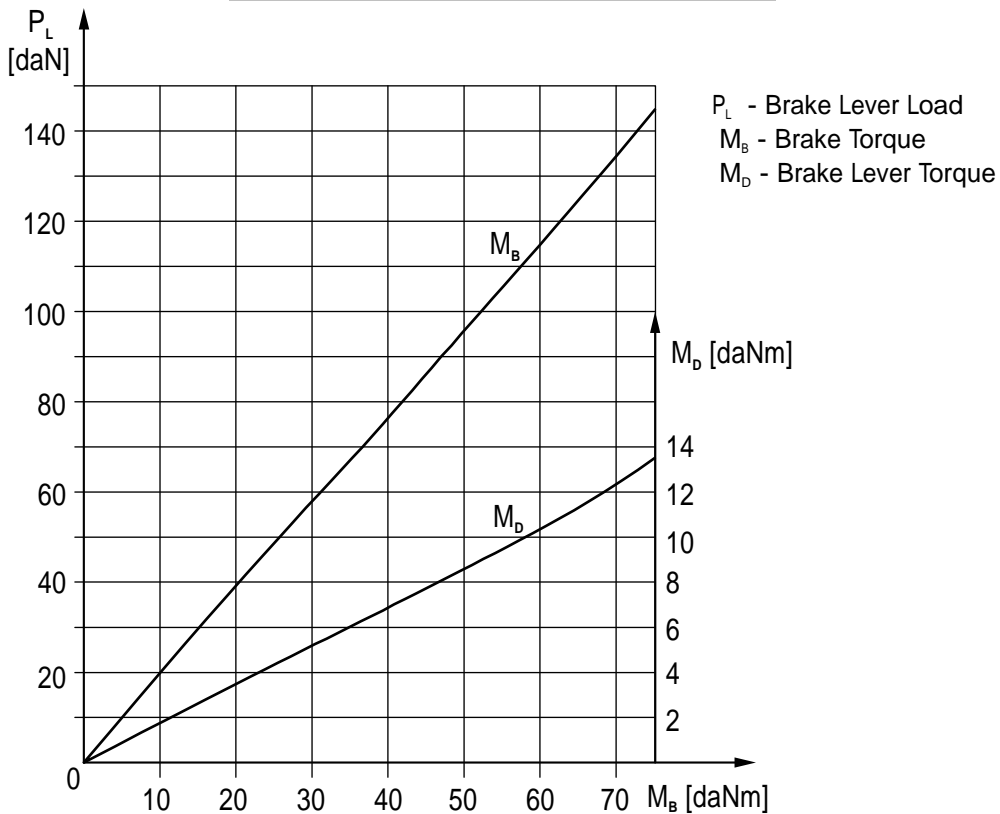

**MAX. PERMISSIBLE SHAFT SEAL PRESSURE**

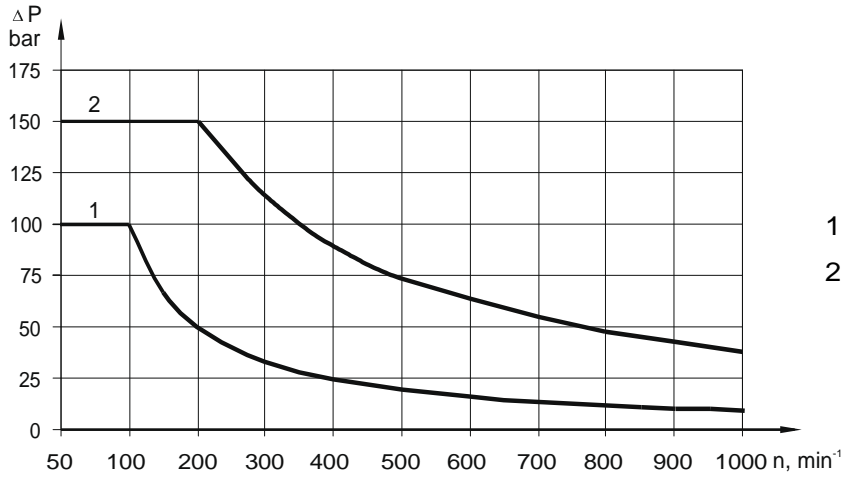

- 1: Drawing for Standard Shaft Seal
- 2: Drawing for High Pressure Seal ("U" Seal)

**MOTORS WITH TACHO CONNECTION**

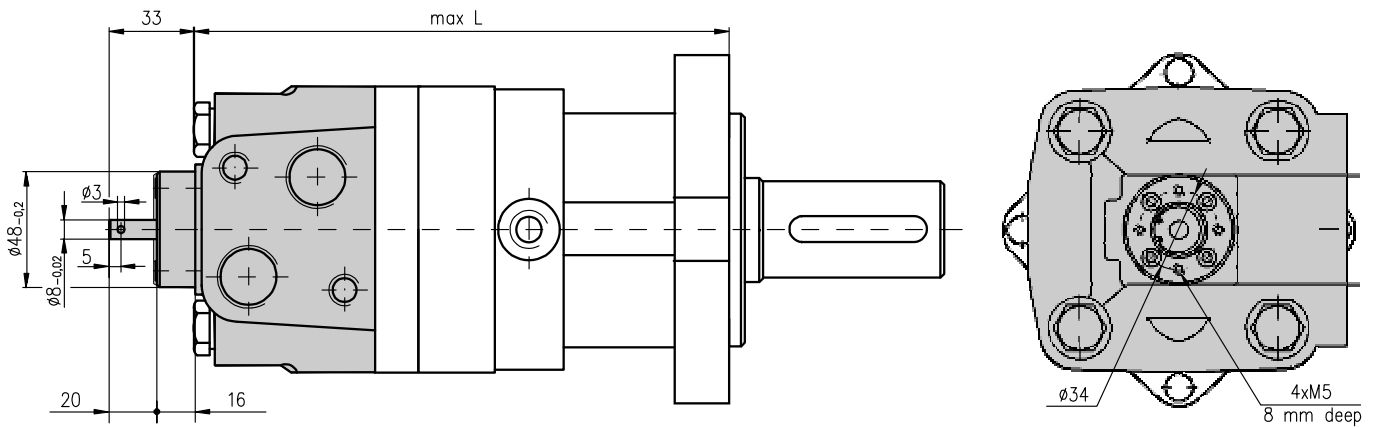

**DIMENSIONS AND MOUNTING DATA - MSS, MSV and MSU**

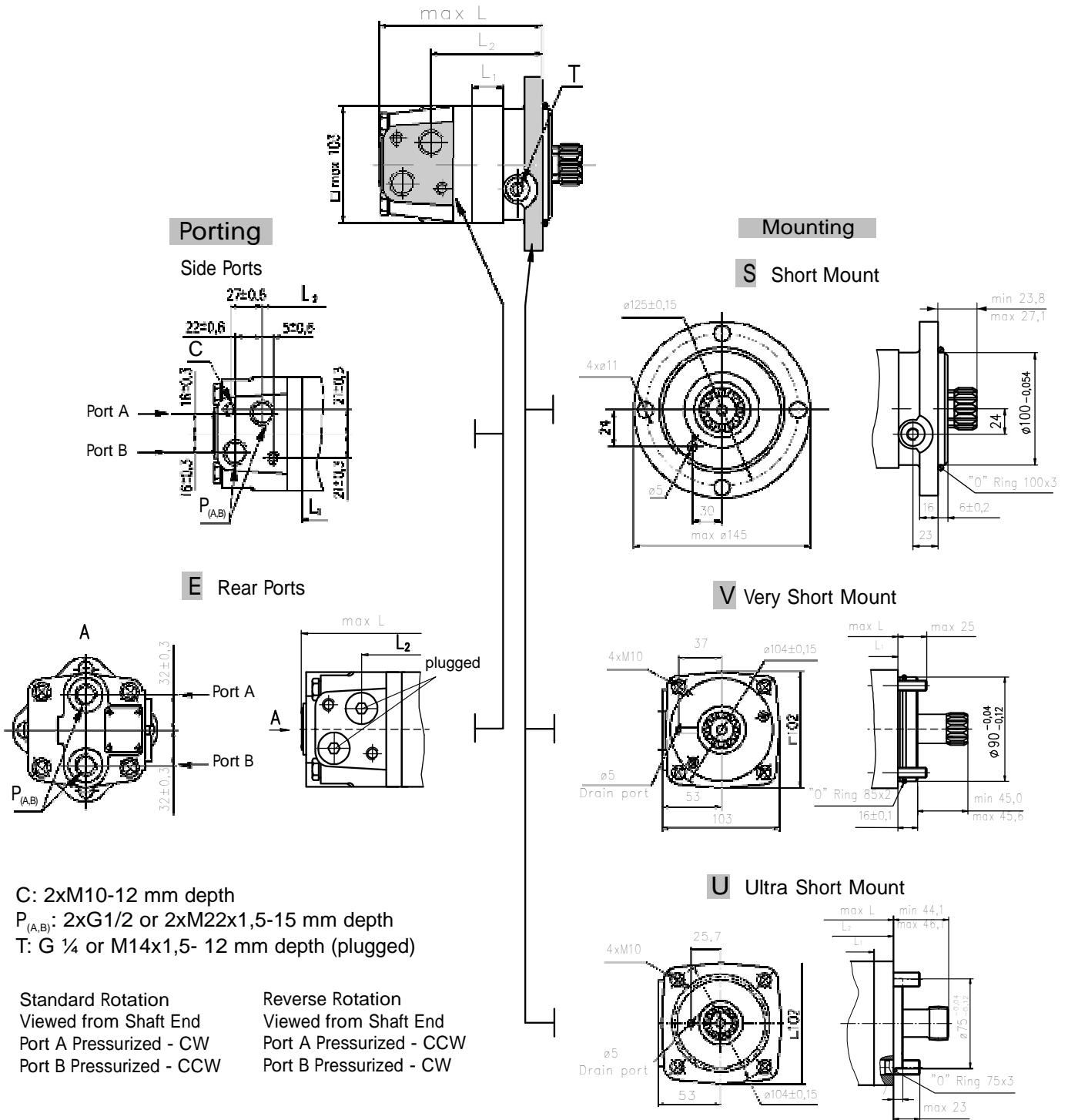

Type	L, mm	L <sub>2</sub> , mm	Type	L, mm	Type	L, mm	L <sub>2</sub> , mm	Type	L, mm	Type	L, mm	L <sub>2</sub> , mm	Type	L, mm	L <sub>1</sub> , mm
MSS 80	125	83	MSSE 80	134	MSV 80	91	52	MSVE 80	97	MSU 80	105,5	63	MSUE 80	111,5	14
MSS 100	129	87	MSSE 100	138	MSV 100	94	55,5	MSVE 100	100	MSU 100	109	66,5	MSUE 100	115	17,4
MSS 125	133	90	MSSE 125	141	MSV 125	100	60	MSVE 125	105	MSU 125	113	71	MSUE 125	119	21,8
MSS 160	139	96	MSSE 160	147	MSV 160	106	66	MSVE 160	111	MSU 160	119	77	MSUE 160	125	27,8
MSS 200	146	103	MSSE 200	154	MSV 200	113	73	MSVE 200	118	MSU 200	126	84	MSUE 200	132	34,8
MSS 250	155	112	MSSE 250	163	MSV 250	121	81,5	MSVE 250	126	MSU 250	135	92,5	MSUE 250	141	43,5
MSS 315	166	123	MSSE 315	174	MSV 315	133	93	MSVE 315	138	MSU 315	146	104	MSUE 315	152	54,8
MSS 400	181	138	MSSE 400	189	MSV 400	147	108	MSVE 400	153	MSU 400	161	118,5	MSUE 400	167	69,4
MSYS 475	194	152	MSYS 475	203	MSYV 475	161	121	MSYVE 475	166						82,6

**DIMENSIONS OF THE ATTACHED COMPONENT**

**For MSS**

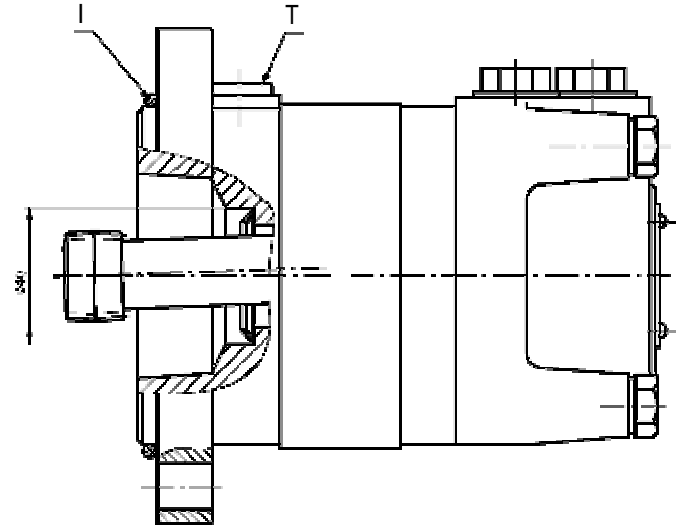
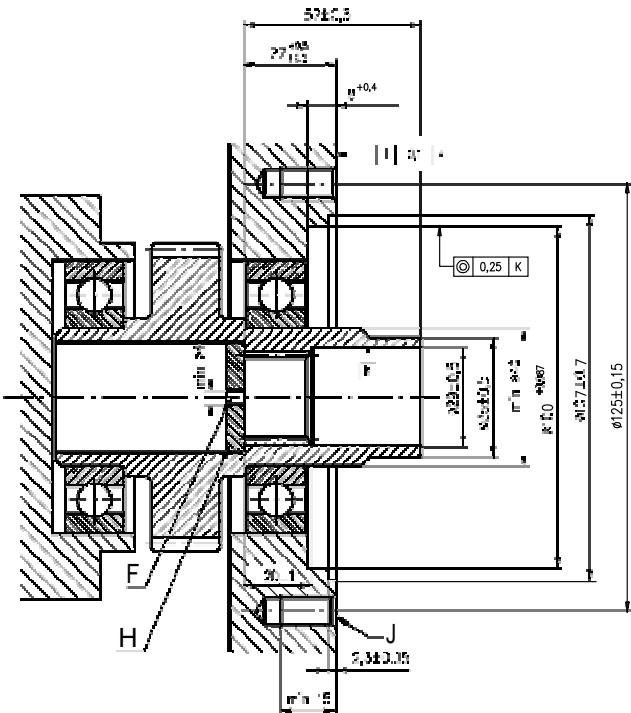

F: Oil circulation hole  
H: Hardened stop plate

I: O- Ring 100x3mm  
J: 4xM10-16 mm depth, 90°  
T: Drain connection G1/4 or M14x1,5

**For MSV**

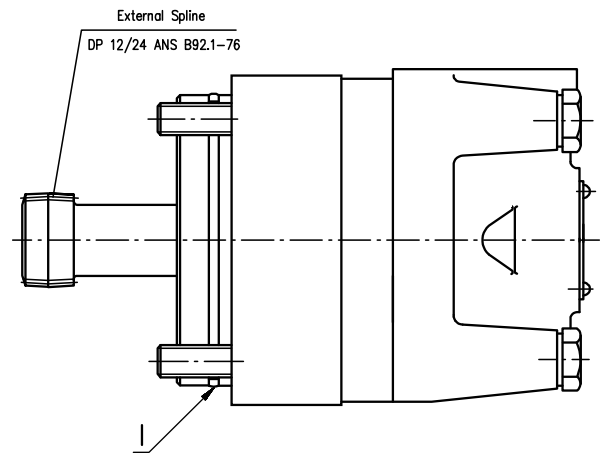
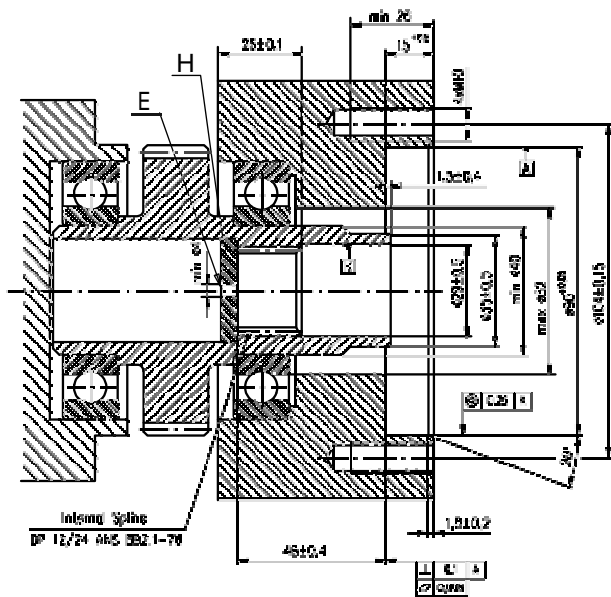

E: External drain hole  
H: Hardened stop plate  
I: O- Ring 85x2mm



**DIMENSIONS OF THE ATTACHED COMPONENT(continued)**

For MSU

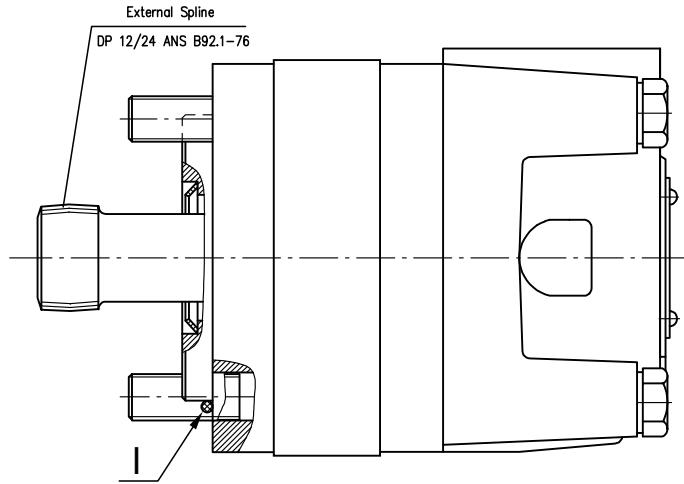
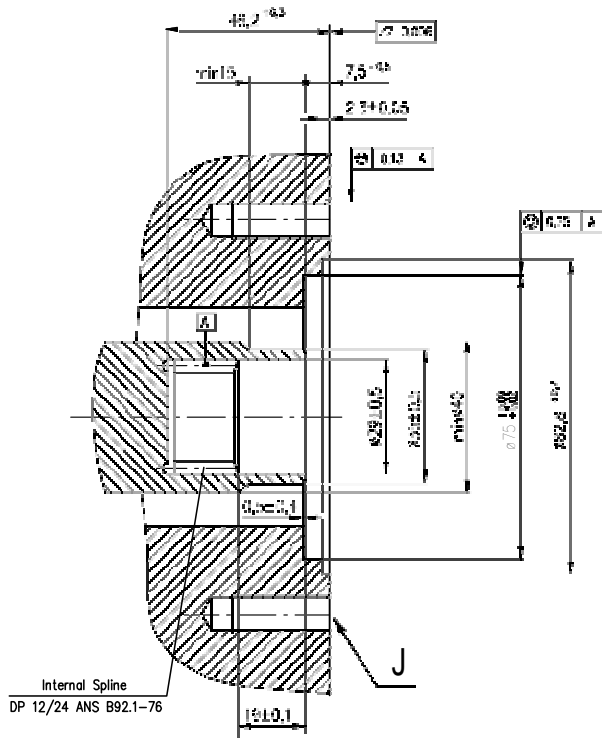

J: 4xM10-26 mm depth, 90°, ø104  
I: O- Ring 75x3 mm

**DRAIN CONNECTION**

A drain line ought to be used when pressure in the return line can exceed the permissible pressure. It can be connected:

- For MSS at the drain port of the motor;
- For MSV and MSU at the drain connection of the attached component. The maximum pressure in the drain line is limited by the attached component and its shaft seal.

The drain line must be possible for oil to flow freely between motor and attached component and must be led to the tank. The maximum pressure in the drain line is limited by the attached component and its seal.

**INTERNAL SPLINE DATA FOR THE ATTACHED COMPONENT**

Standard ANS B92.1-1976, class 5  
[m=2.1166; corrected x.m=+0,8]

Fillet Root Side Fit		mm
Number of Teeth	z	12
Diametral Pitch	DP	12/24
Pressure Angle		30°
Pitch Dia.	D	25,4
Major Dia.	Dri	28,0 <sub>-0,1</sub>
Minor Dia.	Di	23,0 <sup>+0,033</sup>
Space Width [Circular]	Lo	4,308±0,020
Fillet Radius	R	0,2
Max. Measurement between Pin	L	17,62 <sup>+0,15</sup>
Pin Dia.	d	4,835±0,001

Above are when hardened

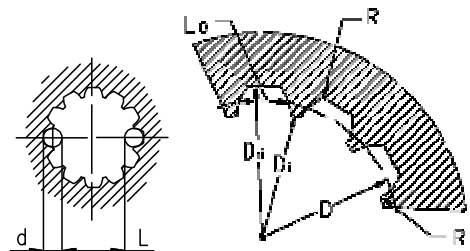

Hardening Specification:  
HRC 60±2  
Effective case depth (HRC 52) 0,7±0,2 mm  
Material 20 MoCr4 DIN 17210 or better

**ORDER CODE**

	1	2	3	4	5	6	7	8	9
MS									

**Pos. 1 - Mounting Flange**

- omit - SAE A-4 mount, four holes
- A - SAE A-2 mount, two holes
- F - Magneto mount, four holes
- Q - Square mount, four holes
- B - Motor with drum brake
- S - Short mount
- V - Very short mount
- U - Ultra short mount
- W - Wheel mount

**Pos. 2 - Port type**

- omit - Side ports
- E - Rear ports

**Pos. 3 - Displacement code**

- 80 - 80,5 [cm<sup>3</sup>/rev]
- 100 - 100,0 [cm<sup>3</sup>/rev]
- 125 - 125,7 [cm<sup>3</sup>/rev]
- 160 - 159,7 [cm<sup>3</sup>/rev]
- 200 - 200,0 [cm<sup>3</sup>/rev]
- 250 - 250,0 [cm<sup>3</sup>/rev]
- 315 - 314,9 [cm<sup>3</sup>/rev]
- 400 - 397,0 [cm<sup>3</sup>/rev]

**Pos. 4 - Shaft Extensions\***

- C -  $\varnothing$ 32 straight, Parallel key A10x8x45 DIN6885
- CO -  $\varnothing$ 1 $\frac{1}{4}$ " straight, Parallel key  $\frac{5}{16}$ "x $\frac{5}{16}$ "x1 $\frac{1}{4}$ " BS46
- K -  $\varnothing$ 35 tapered 1:10, Parallel key B6x6x20 DIN6885
- SL -  $\varnothing$ 34,85 p.t.o. DIN 9611 Form 1
- SH -  $\varnothing$ 1 $\frac{1}{4}$ " splined 14T ANSI B92.1-1976

**Pos. 5 - Shaft Seal Version (see page 17)**

- omit - Low pressure seal
- U - High pressure seal

**Pos. 6 - Ports**

- omit - BSPP (ISO 228)
- M - Metric (ISO 262)

**Pos. 7 - Actuating Direction\*\***

- /R - Right
- /L - Left

**Pos. 8 - Special Features (see page 50)**

**Pos. 9 - Design Series**

- omit - Factory specified

**NOTES:**

- \* The permissible output torque for shafts must not be exceeded!
- \*\* Only for MSB

The hydraulic motors are mangano-phosphatized as standard.

ООО «Кама-Флекс-Гидравлика» (8552) 44-33-58

<http://www.oookfg.narod.ru>

e-mail: kama-hydraulic@narod.ru