

HYDRAULIC MOTOR-BRAKE B/MR

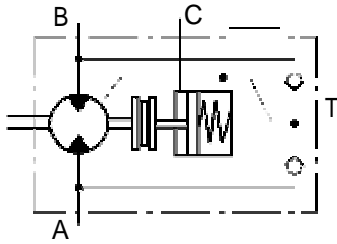

APPLICATION

- » Conveyors
- » Feeding mechanism of robots and manipulators
- » Metal working machines
- » Textile machines
- » Machines for agriculture
- » Food industries
- » Mining machinery etc.

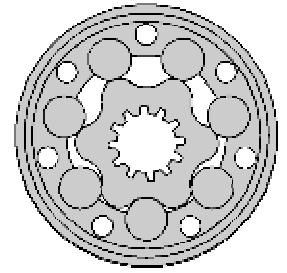

CONTENTS

Specification data	49÷50
Dimensions and mounting	51
Shaft extensions	51
Permissible shaft loads	52
Permissible shaft Seal Pressure ...	52
Order code	52

OPTIONS

- » Model- Spool valve, roll-gerotor;
- » Fully integrated friction disk brake;
- » Side port;
- » Shaft - straight;
- » BSPP ports.

GENERAL

Displacement, [cm ³ /rev.]	80,3÷397
Max. Speed, [RPM]	150÷500
Max. Torque, [daNm]	19,5÷55
Max. Output, [kW]	2,2÷16
Max. Pressure Drop, [bar]	45÷175
Max. Oil Flow, [l/min]	40÷60
Min. Speed, [RPM]	10
Permissible Shaft Loads, [daN]	P _a =200
Pressure fluid	Mineral based- HLP(DIN 51524) or HM(ISO 6743/4)
Temperature range, [°C]	-30÷90
Optimal Viscosity range, [mm ² /s]	20÷75
Filtration	ISO code 20/16 (Min. recommended fluid filtration of 25 micron)

Oil flow in drain line

Pressure drop (bar)	Viscosity (mm ² /s)	Oil flow in drain line (l/min)
100	20	2,5
	35	1,8
140	20	3,5
	35	2,8

Pressure Losses

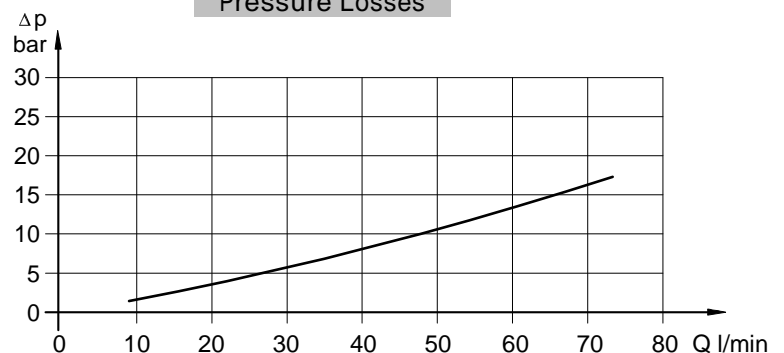



SPECIFICATION DATA

Type	B/MR 80	B/MR 100	B/MR 125	B/MR 160 C	B/MR 160 CB	B/MR 200 C	B/MR 200 CB	
Displacement, cm. ³ /rev.	80,3	99,8	125,7	159,6		199,8		
Max. Speed, [min ⁻¹]	Cont.	500	500	475	375		300	
	Int.*	600	600	600	470		375	
Max. Torque [daNm]	Cont.	19,5	24	30	30	39	30	45
	Int.*	22	28	34	39	43	39	50
	Peak**)	27	32	37	46	46	56	56
Max. Output [kW]	Cont.	16,6	18,6	12,5	10	11,5	7,8	11
	Int.*	16	16	14,5	12,5	14	12,4	13
Max. Pressure Drop, [bar]	Cont.	175	175	175	135	175	105	175
	Int.*	200	200	200	175	200	145	200
	Peak**	225	225	225	225	225	225	225
Max. Oil Flow [l/min]	Cont.	40	50	60	60		60	
	Int.*	48	60	75	75		75	
Max. Inlet Pressure [bar]	Cont.	175						
	Int.*	200						
	Peak**	225						
Max. Starting Pressure [bar]	10	10	9	7		5		
Min. Starting Torque, [daNm]	At max.press.dropCont	15	20	25	24	32	26	41
	At max.press.dropInt.*	17	23	28	32	37	33	46
Min. Speed***, [min ⁻¹]	10	10	10	10	10	10	10	
Static Torque of Brake, [daNm]	55							
Min. Brake Release Pressure****, [bar]	21							
Max. Opening Pressure, [bar]	200							
Weight, [kg]	11,0	11,2	11,4	11,6	11,7	12,2	12,3	

* Intermittent operation: the permissible values may occur for max. 10% of every minute.

** Peak load: the permissible values may occur for max. 1% of every minute.

*** For speeds of 10 RPM or lower, consult factory or your regional manager.

**** Motor-brakes must always have a drain line. The brake release pressure is the difference between the pressure in the brake release line and the pressure in the drain line.

1. Intermittent speed and intermittent pressure drop must not occur simultaneously.
2. Recommended filtration is per ISO cleanliness code 20/16. A nominal filtration of 25 micron or better.
3. Recommended using a premium quality, anti-wear type mineral based hydraulic oil HLP(DIN51524) or HM (ISO 6743/4).
If using synthetic fluids consult the factory for alternative seal materials.
4. Recommended minimum oil viscosity 13 mm²/s at operating temperatures.
5. Recommended maximum system operating temperature is 82°C.
6. To assure optimum motor life fill with fluid prior to loading and run at moderate load and speed for 10-15 minutes.



SPECIFICATION DATA (continued)

Type		B/MR 250 C	B/MR 250 CB	B/MR 315 C	B/MR 315 CB	B/MR 400 C	B/MR 400 CB
Displacement, cm. ³ /rev.		250,1		315,7		397	
Max. Speed, [min ⁻¹]	Cont.	240		190		150	
	Int.*	300		240		190	
Max. Torque [daNm]	Cont.	30	54	30	55	30	55
	Int.*	39	57	42	57	43	57
	Peak**)	60	71	61	71	60	70
Max. Output [kW]	Cont.	6,2	10	4,5	9	2,2	7
	Int.*	9,5	11	7,5	10	5,6	8,7
Max. Pressure Drop, [bar]	Cont.	85	175	65	135	45	105
	Int.*	115	185	90	145	75	115
	Peak**	200	225	150	180	120	140
Max. Oil Flow [l/min]	Cont.	60					
	Int.*	75					
Max. Inlet Pressure [bar]	Cont.	175					
	Int.*	200					
	Peak**	225					
Max. Starting Pressure [bar]		5		5		5	
Min. Starting Torque, [daNm]	At max.press.drop Cont	24	50	26	50	24	44
	At max.press.drop Int.*	31	51,5	35	51,8	38	50
Min. Speed***, [min ⁻¹]		10	10	10	10	10	10
Static Torque of Brake, [daNm]		55					
Min. Brake Release Pressure****, [bar]		21					
Max. Opening Pressure, [bar]		200					
Weight, [kg]		12,6	12,7	13,3	13,4	14	14,1

* Intermittent operation: the permissible values may occur for max. 10% of every minute.

** Peak load: the permissible values may occur for max. 1% of every minute.

*** For speeds of 10 RPM or lower, consult factory or your regional manager.

**** Motor-brakes must always have a drain line. The brake release pressure is the difference between the pressure in the brake release line and the pressure in the drain line.

1. Intermittent speed and intermittent pressure drop must not occur simultaneously.
2. Recommended filtration is per ISO cleanliness code 20/16. A nominal filtration of 25 micron or better.
3. Recommended using a premium quality, anti-wear type mineral based hydraulic oil HLP(DIN51524) or HM (ISO 6743/4).
If using synthetic fluids consult the factory for alternative seal materials.
4. Recommended minimum oil viscosity 13 mm²/s at operating temperatures.
5. Recommended maximum system operating temperature is 82°C.
6. To assure optimum motor life fill with fluid prior to loading and run at moderate load and speed for 10-15 minutes.

OUTLINE DIMENSINS REFERENCE

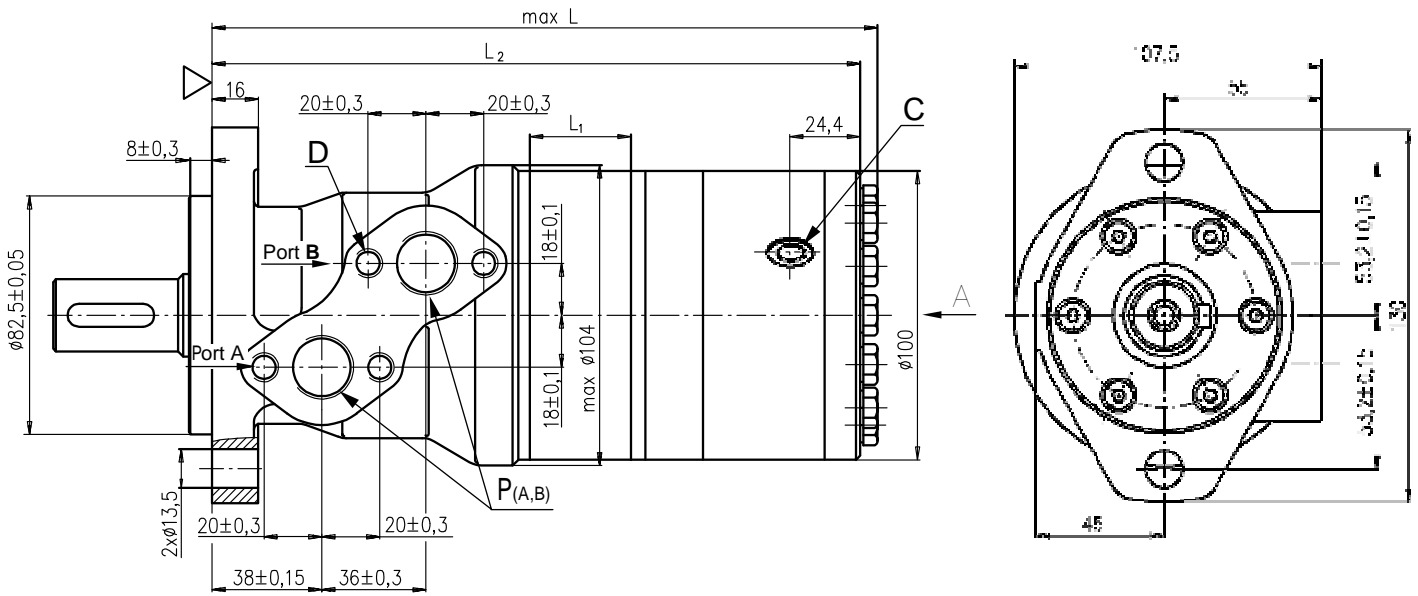

- D : 4xM8 - 13 mm depth
- C : G1/4 - 12 mm depth
- P_(A, B): 2xG1/2 - 15 mm depth
- T : G1/4 - 10 mm depth

Type	L ₁ , mm	L ₂ , mm	L _{max} , mm
B/MR 80	14,0	205,5	213,5
B/MR 100	17,4	209,0	217,0
B/MR 125	21,8	213,5	221,5
B/MR 160	27,8	219,5	227,5
B/MR 200	34,8	226,5	234,5
B/MR 250	43,5	235,0	243,0
B/MR 315	54,8	246,5	254,5
B/MR 400	69,4	261,0	269,0

Standard Rotation
Viewed from Shaft End
Port A Pressurized - CW
Port B Pressurized - CCW

Reverse Rotation
Viewed from Shaft End
Port A Pressurized - CCW
Port B Pressurized - CW

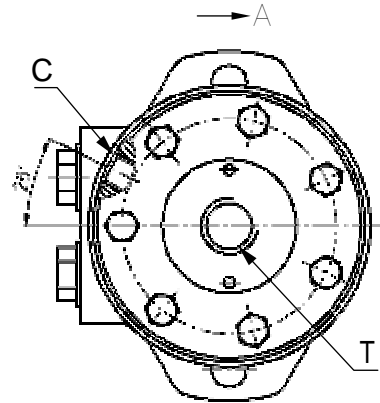

▽- Motor Mounting Surface

SHAFT EXTENSIONS

C - $\varnothing 25$ straight, Parallel key A8x7x32 DIN 6885
Max. Torque 34 daNm

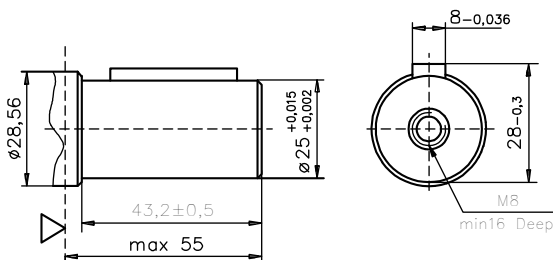

CB - $\varnothing 32$ straight, Parallel key A10x8x45 DIN 6885
Max. Torque 77 daNm

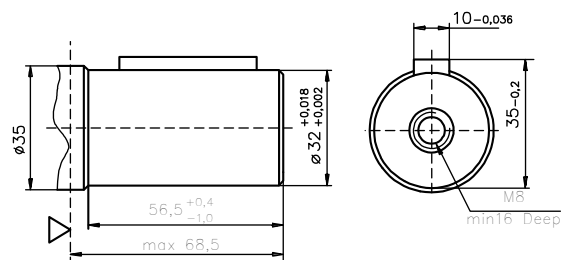

PERMISSIBLE SHAFT LOADS

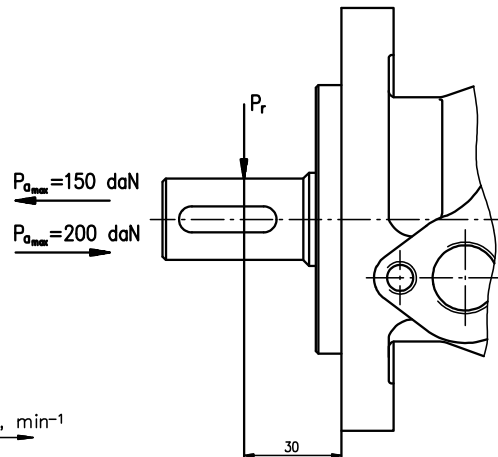
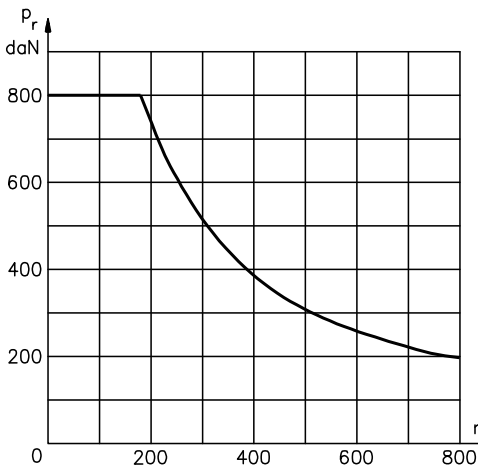

For Rotation speed $n \geq 200 \text{ min}^{-1}$ and distance $L \leq 30 \text{ mm}$ the radial load could be calculated by

$$P_r = \frac{800}{n} \times \frac{25\,000}{95+L}, \text{ daN}$$

MAX. PERMISSIBLE SHAFT SEAL PRESSURE

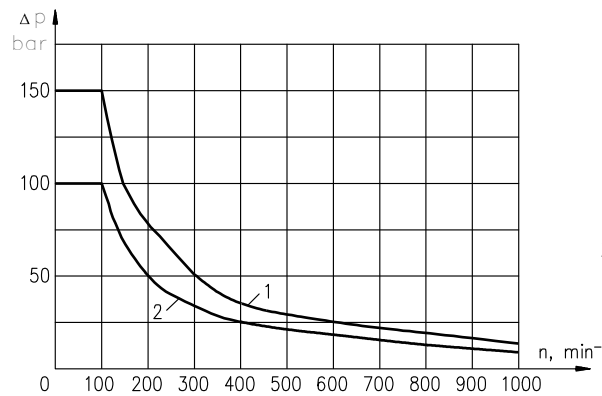

1: Drawing for "C" shaft
2: Drawing for "CB" shaft

ORDER CODE

	1	2	3	4
B/MR				

Pos. 1 - Displacement code

80	- 80,3 [cm³/rev]
100	- 99,8 [cm³/rev]
125	- 125,7 [cm³/rev]
160	- 159,6 [cm³/rev]
200	- 199,8 [cm³/rev]
250	- 250,1 [cm³/rev]
315	- 315,7 [cm³/rev]
400	- 397,0 [cm³/rev]

Pos. 2 - Shaft Extensions*

C	- ø25 straight, Parallel key A8x7x32 DIN 6885
CB	- ø32 straight, Parallel key A10x8x45 DIN 6885

Pos. 3 - Special Features (see page 53)

Pos. 4 - Design Series

omit - Factory specified

NOTES:

* The permissible output torque for shafts must be not exceeded!

The hydraulic motors are mangano phosphatized as standard.

ООО «Кама-Флекс-Гидравлика» (8552) 44-33-58

<http://www.oookfg.narod.ru>

e-mail: kama-hydraulic@narod.ru