

HYDRAULIC MOTORS RW

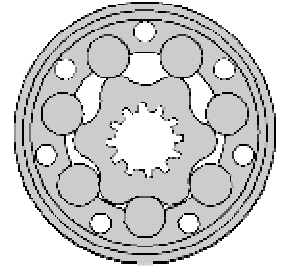

APPLICATION

- » Conveyors
- » Feeding mechanism of robots and manipulators
- » Metal working machines
- » Textile machines
- » Machines for agriculture
- » Food industries
- » Grass cutting machinery etc.



CONTENTS

| | |
|-------------------------------------|---------|
| Specification data |25 |
| Function diagrams | 26÷30 |
| Permissible shaft Seal Pressure ... | 30 |
| Dimensions and mounting | 31 |
| Permissible shaft loads | 31 |
| Shaft extensions | 32 |
| Order code | 32 |

OPTIONS

- » Model- Spool valve, roll-gerotor
- » Wheel mount
- » Shafts- straight and tapered
- » Metric and BSPP ports
- » Other special features

GENERAL

| | |
|---|---|
| Displacement, [cm ³ /rev.] | 51,5÷397 |
| Max. Speed, [RPM] | 150÷775 |
| Max. Torque, [daNm] | 10÷61 |
| Max. Output, [kW] | 7÷13 |
| Max. Pressure Drop, [bar] | 110÷175 |
| Max. Oil Flow, [l/min] | 40÷60 |
| Min. Speed, [RPM] | 10 |
| Pressure fluid | Mineral based- HLP(DIN 51524) or HM(ISO 6743/4) |
| Temperature range, [°C] | -30÷90 |
| Optimal Viscosity range, [mm ² /s] | 20÷75 |
| Filtration | ISO code 20/16 (Min. recommended fluid filtration of 25 micron) |

Oil flow in drain line

| Pressure drop (bar) | Viscosity (mm ² /s) | Oil flow in drain line (l/min) |
|---------------------|--------------------------------|--------------------------------|
| 100 | 20 | 2,5 |
| | 35 | 1,8 |
| 140 | 20 | 3,5 |
| | 35 | 2,8 |

Pressure Losses

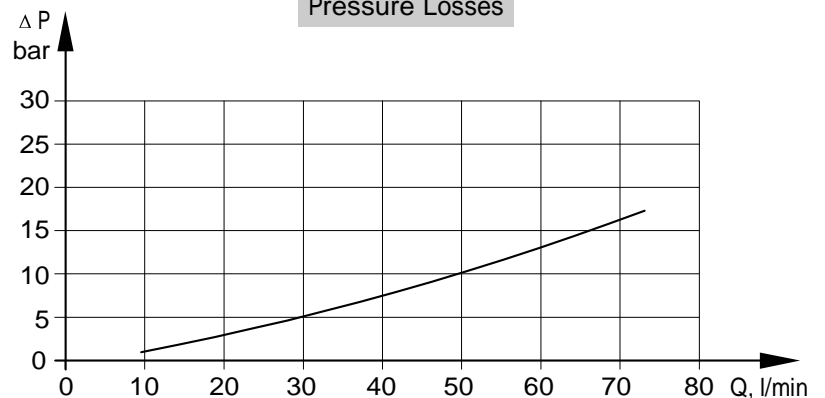

SPECIFICATION DATA

| Type | | RW | | | | | | | | |
|--|------------------------------|------|------|------|-------|-------|-------|-------|-------|------|
| | | 50 | 80 | 100 | 125 | 160 | 200 | 250 | 315 | 400 |
| Displacement, [cm ³ /rev.] | | 51,5 | 80,3 | 99,8 | 125,7 | 159,6 | 199,8 | 250,1 | 315,7 | 397 |
| Max. Speed, [RPM] | cont. | 775 | 750 | 600 | 475 | 375 | 300 | 240 | 190 | 150 |
| | int.* | 970 | 940 | 750 | 600 | 470 | 375 | 300 | 240 | 190 |
| Max. Torque [daNm] | cont. | 10 | 20 | 24 | 30 | 39 | 45 | 54 | 55 | 61 |
| | int.* | 13 | 22 | 28 | 34 | 43 | 50 | 61 | 69 | 69 |
| | peak** | 17 | 27 | 32 | 37 | 46 | 56 | 71 | 84 | 87 |
| Max. Output, [kW] | cont. | 7 | 12,5 | 13 | 12,5 | 11,5 | 11 | 10 | 9 | 7,8 |
| | int.* | 8,5 | 15 | 15 | 14,5 | 14 | 13 | 12 | 10 | 10,6 |
| Max. Pressure | cont. | 140 | 175 | 175 | 175 | 175 | 175 | 175 | 135 | 110 |
| Drop [bar] | int.* | 175 | 200 | 200 | 200 | 200 | 200 | 200 | 175 | 140 |
| | peak** | 225 | 225 | 225 | 225 | 225 | 225 | 225 | 210 | 175 |
| Max. Oil Flow [l/min] | cont. | 40 | 60 | 60 | 60 | 60 | 60 | 60 | 60 | 60 |
| | int.* | 50 | 75 | 75 | 75 | 75 | 75 | 75 | 75 | 75 |
| Max. Inlet Pressure [bar] | cont. | 175 | 175 | 175 | 175 | 175 | 175 | 175 | 175 | 175 |
| | int.* | 200 | 200 | 200 | 200 | 200 | 200 | 200 | 200 | 200 |
| | peak** | 225 | 225 | 225 | 225 | 225 | 225 | 225 | 225 | 225 |
| Max. Return Pressure with Drain Line [bar] | cont. | 175 | 175 | 175 | 175 | 175 | 175 | 175 | 175 | 175 |
| | int.* | 200 | 200 | 200 | 200 | 200 | 200 | 200 | 200 | 200 |
| | peak** | 225 | 225 | 225 | 225 | 225 | 225 | 225 | 225 | 225 |
| Max. Starting Pressure with Unloaded Shaft, [bar] | | 10 | 10 | 10 | 9 | 7 | 5 | 4 | 3 | 3 |
| Min. Starting Torque [daNm] | at max. press. drop cont. | 8 | 15 | 20 | 25 | 32 | 41 | 50 | 50 | 50 |
| | at max. press. drop int.* | 10 | 17 | 23 | 28 | 37 | 46 | 55 | 66 | 61 |
| Min. Speed***, [RPM] | | 10 | 10 | 10 | 10 | 10 | 10 | 10 | 10 | 10 |
| Weight, avg. [kg] | | 10,4 | 10,5 | 10,6 | 10,8 | 11,1 | 11,6 | 12,1 | 12,6 | 13,3 |

* Intermittent operation: the permissible values may occur for max. 10% of every minute.

** Peak load: the permissible values may occur for max. 1% for every minute.

*** For speeds of 10 RPM or lower, consult factory or your regional manager.

1. Intermittent speed and intermittent pressure drop must not occur simultaneously!
2. Recommended filtration is per ISO cleanliness code 20/16. A nominal filtration of 25 micron or better.
3. Recommended using a premium quality, anti-wear type mineral based hydraulic oil HLP(DIN51524) or HM (ISO 6743/4).
If using synthetic fluids consult the factory for alternative seal materials.
4. Recommended minimum oil viscosity 13 mm²/s at operating temperatures.
5. Recommended maximum system operating temperature - 82°C.
6. To assure optimum motor life fill with fluid prior to loading and run at moderate load and speed for 10-15 min.

FUNCTION DIAGRAMS

RW 50

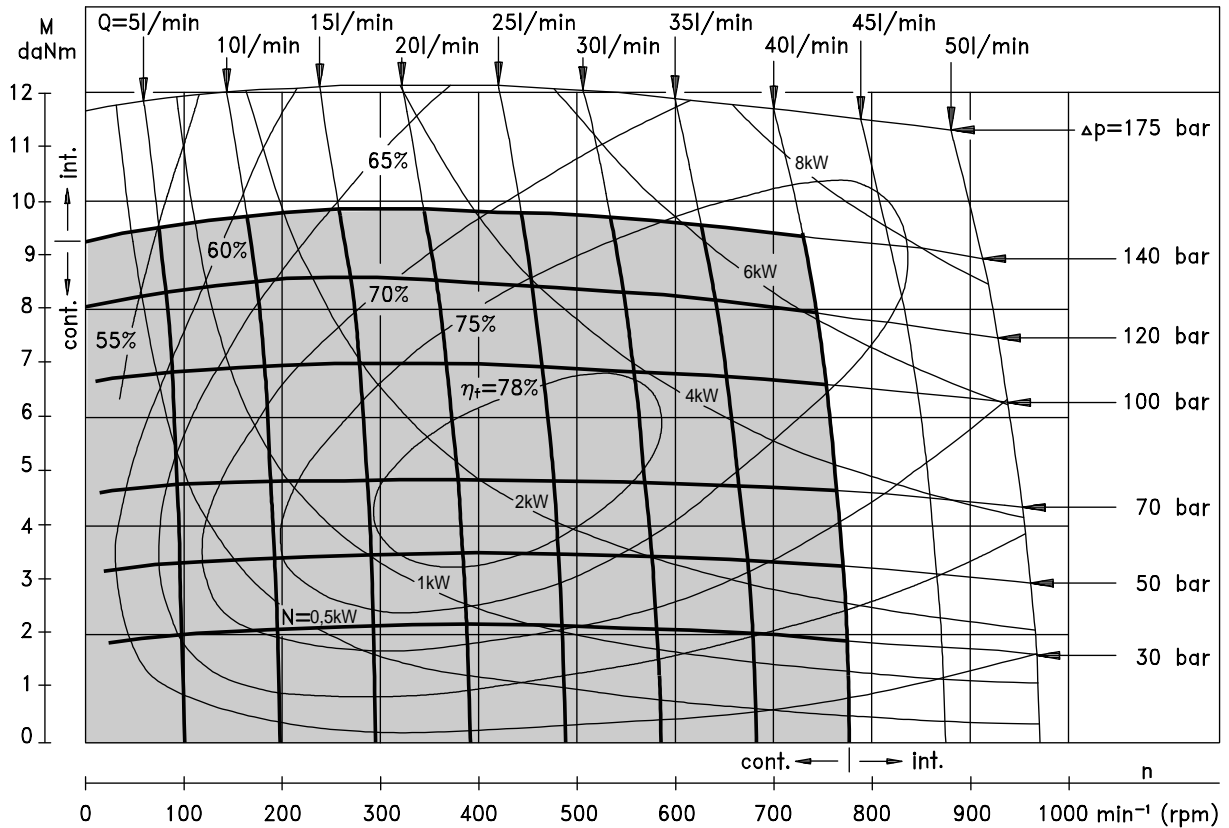

RW 80

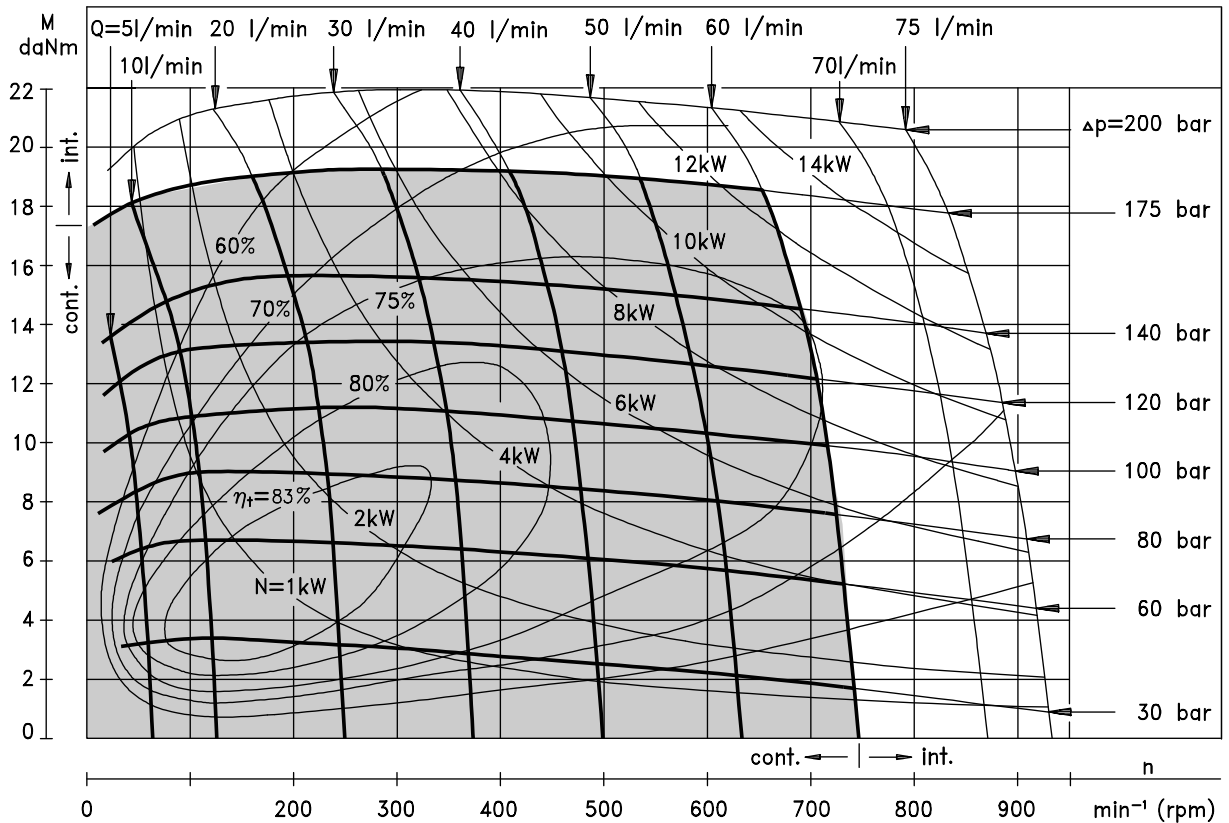

The function diagrams data was collected at back pressure 5÷10 bar and oil with viscosity of 32 mm²/s at 50° C.

FUNCTION DIAGRAMS

RW 100

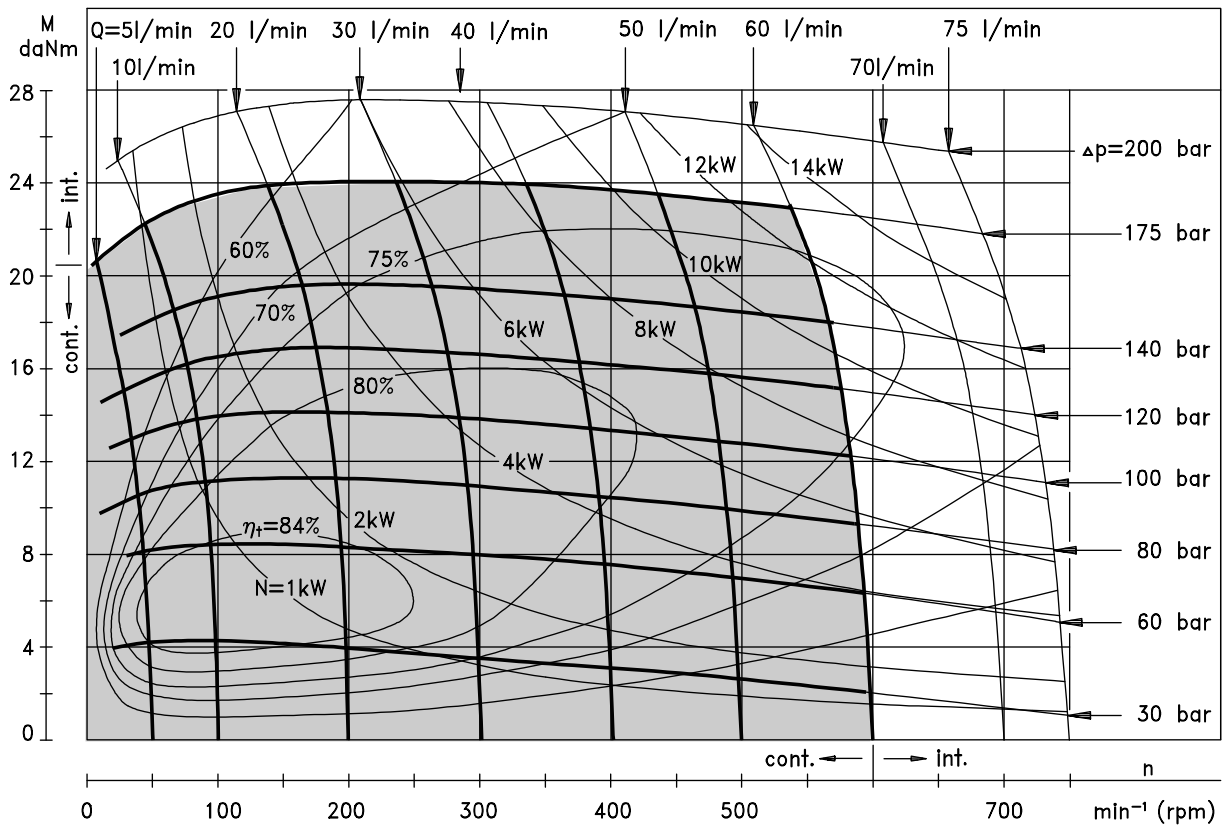

RW 125

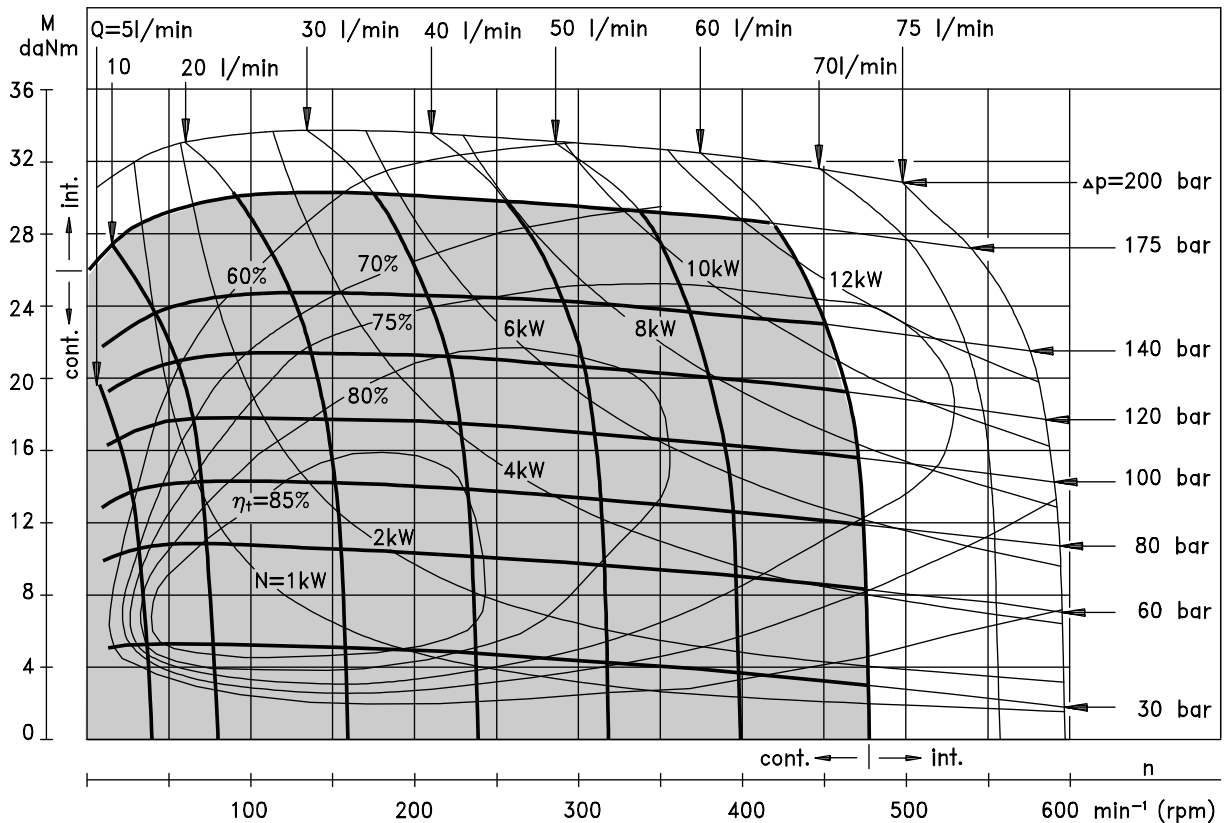

The function diagrams data was collected at back pressure 5÷10 bar and oil with viscosity of 32 mm²/s at 50° C.

FUNCTION DIAGRAMS

RW 160

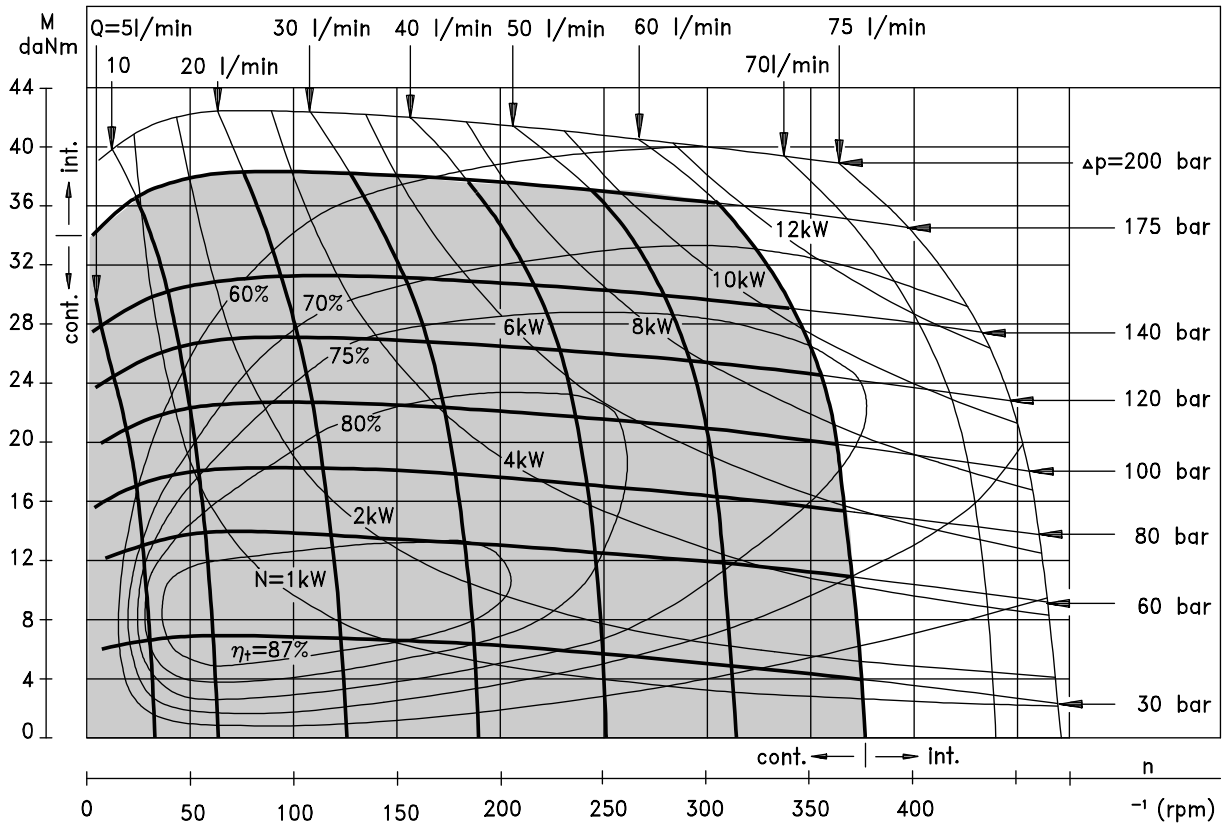

RW 200

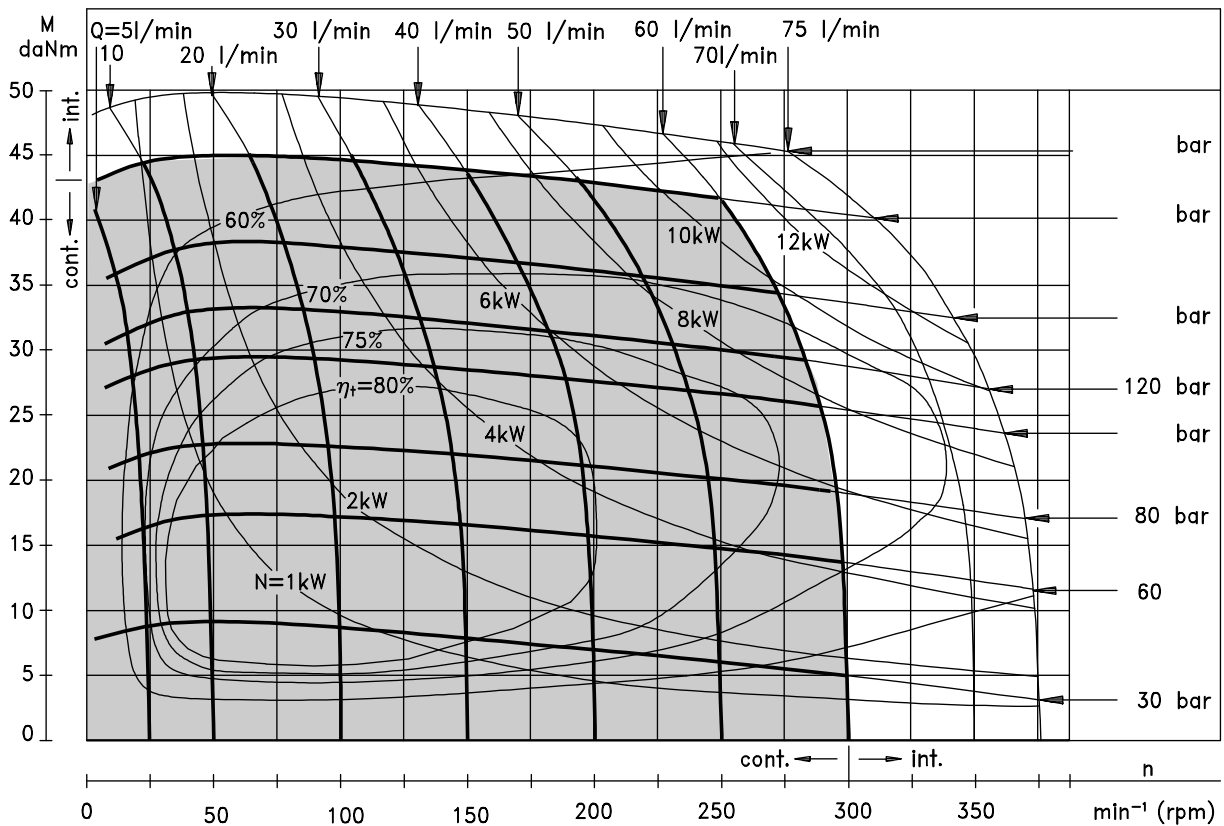

The function diagrams data was collected at back pressure $5 \div 10$ bar and oil with viscosity of $32 \text{ mm}^2/\text{s}$ at 50°C .

FUNCTION DIAGRAMS

RW 250

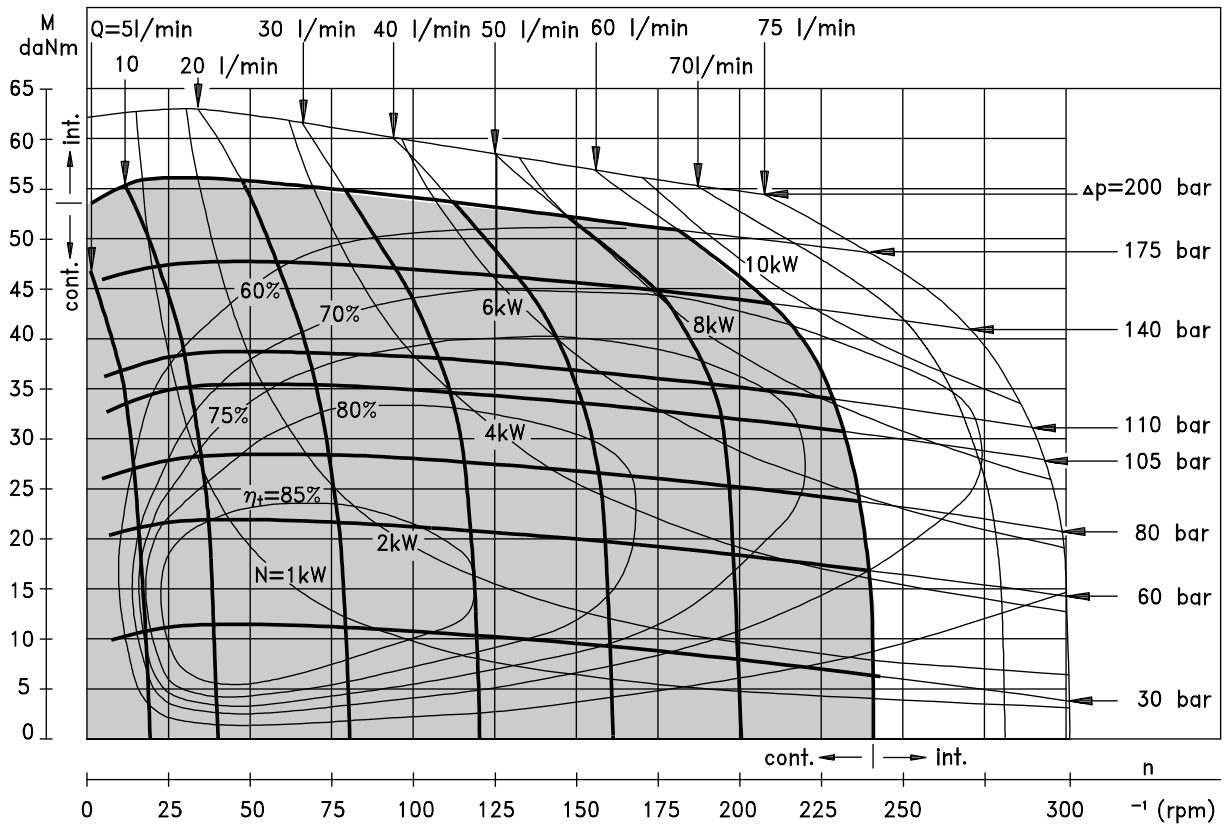

RW 315

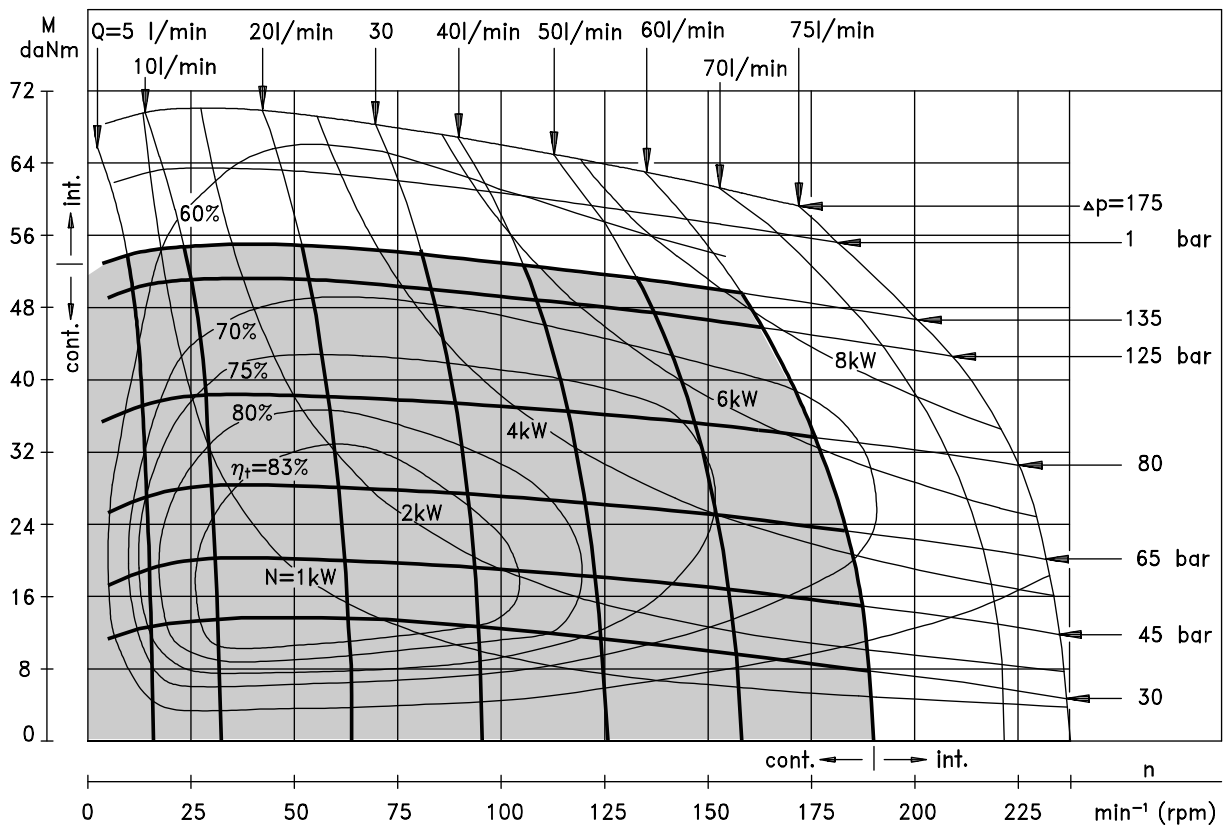

The function diagrams data was collected at back pressure 5÷10 bar and oil with viscosity of 32 mm²/s at 50° C.

FUNCTION DIAGRAM

RW 400

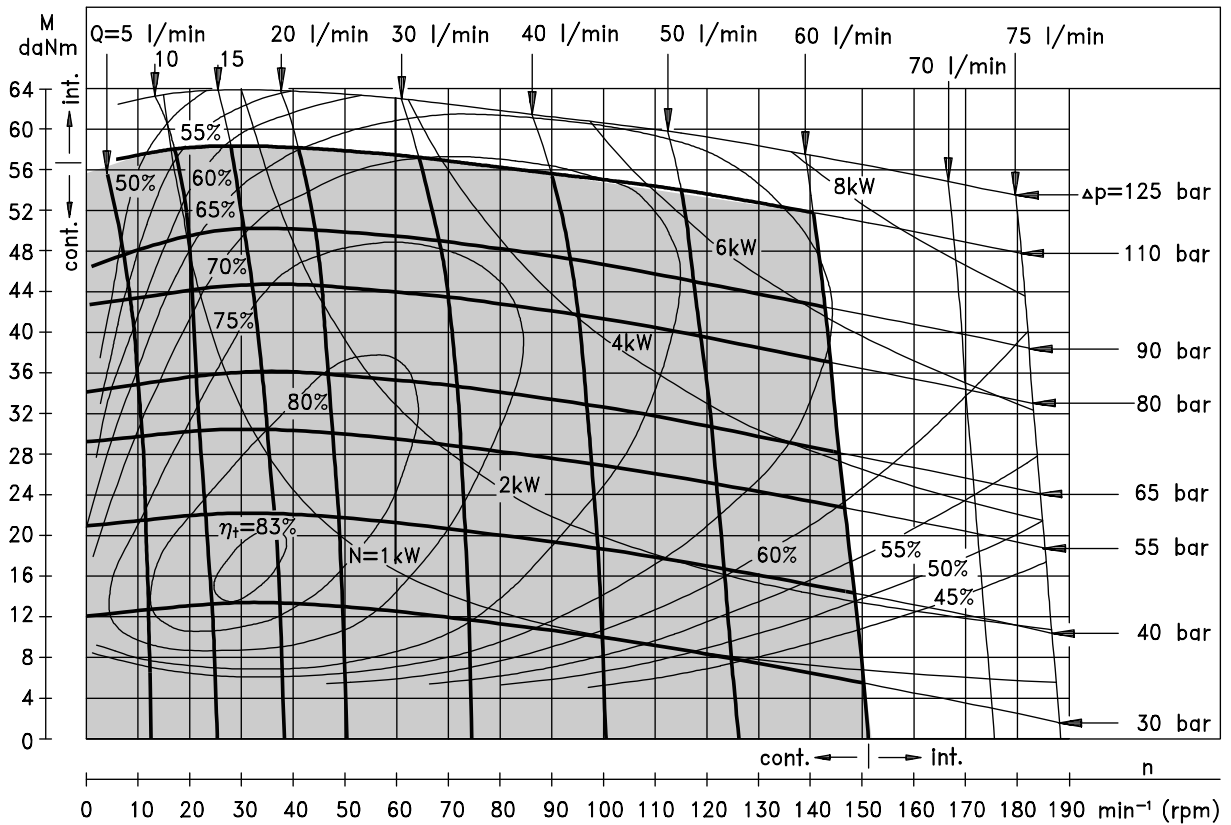

The function diagram data was collected at back pressure 5÷10 bar and oil with viscosity of 32 mm²/s at 50° C.

MAX. PERMISSIBLE SHAFT SEAL PRESSURE

RW...1 motors without drain connection:

The shaft seal pressure never exceeds the pressure in the return line.

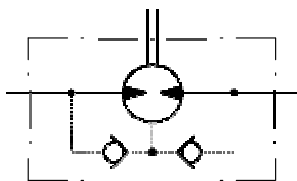

RW... motors with drain connection:

The shaft seal pressure equals the pressure in the drain line.

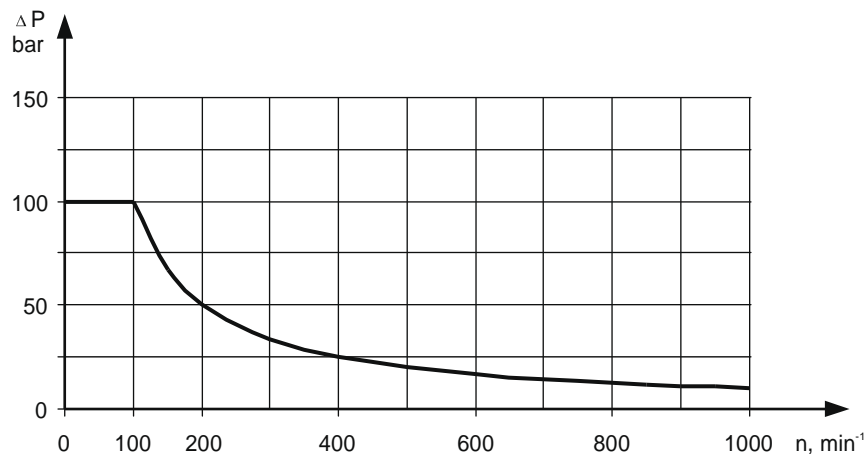
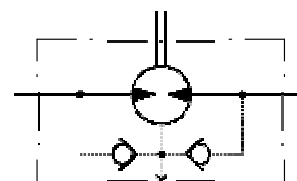

DIMENSIONS AND MOUNTING DATA

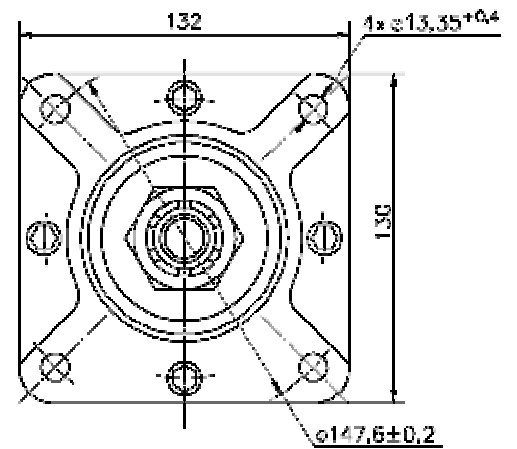
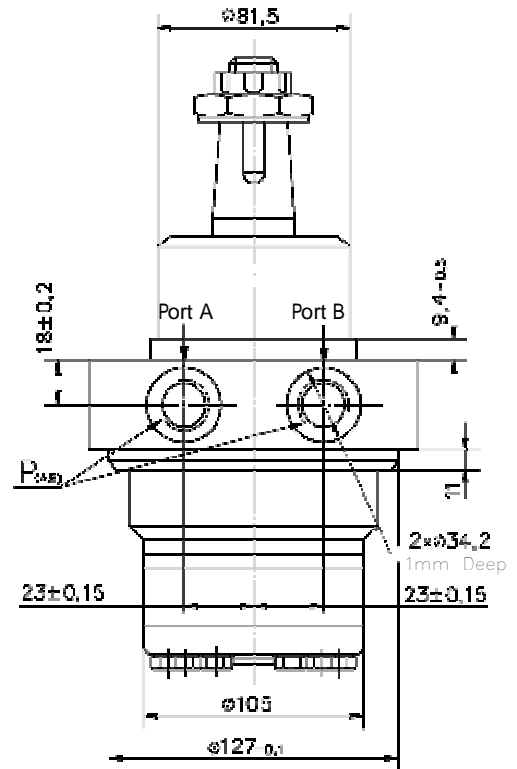
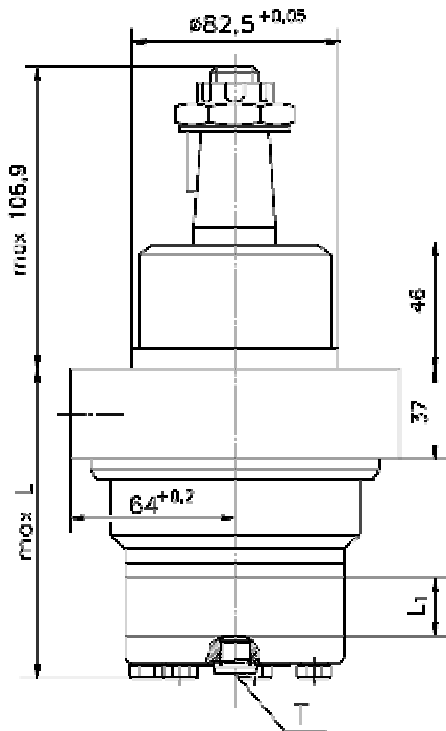

$P_{(A,B)}$: 2xG1/2 or 2xM22x1,5 - 15 mm depth
 T : G1/4 or M14x1,5 - 12 mm depth (plugged)
 Standard Rotation Reverse Rotation
 Viewed from Shaft End Viewed from Shaft End
 Port A Pressurized - CW Port A Pressurized - CCW
 Port B Pressurized - CCW Port B Pressurized - CW

Permissible Shaft Loads

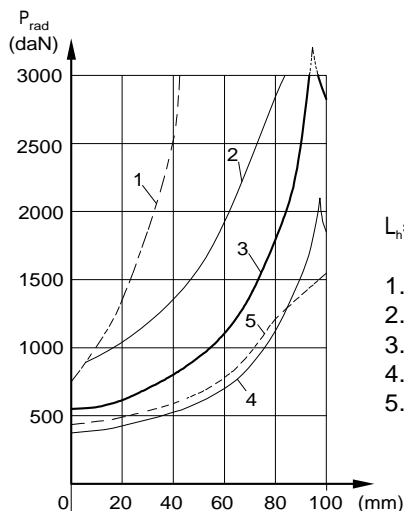

$L_n=2500$ h

1. Permissible radial shaft load
2. Drawing by $n= 50 \text{ min}^{-1}$
3. Drawing by $n=200 \text{ min}^{-1}$
4. Drawing by $n=800 \text{ min}^{-1}$
5. Drawing by $n=200 \text{ min}^{-1}$ and $P_a \text{ max}=500 \text{ daN}$

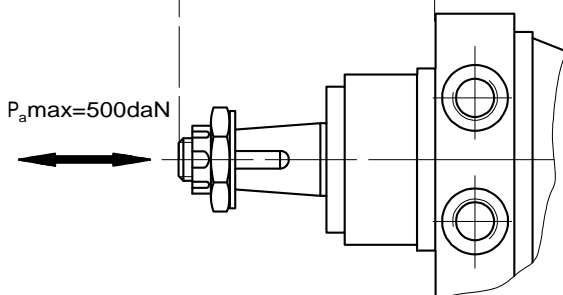

| Type | L, mm | L ₁ , mm |
|--------|-------|---------------------|
| RW 50 | 108,0 | 9,0 |
| RW 80 | 113,0 | 14,0 |
| RW 100 | 116,5 | 17,4 |
| RW 125 | 121,0 | 21,8 |
| RW 160 | 127,0 | 27,8 |
| RW 200 | 134,0 | 34,8 |
| RW 250 | 142,5 | 43,5 |
| RW 315 | 154,0 | 54,8 |
| RW 400 | 168,5 | 69,4 |

SHAFT EXTENSIONS

CB - $\varnothing 32$ straight, Parallel key A10x8x45 DIN 6885
Max. Torque 77 daNm

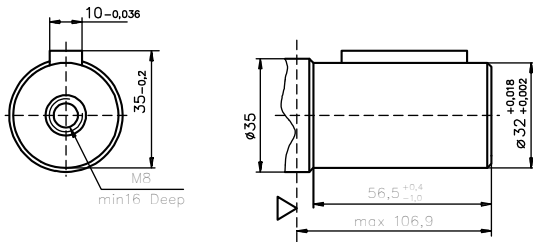

KB - tapered 1:10, Parallel key B6x6x20 DIN 6885
Max. Torque 77 daNm

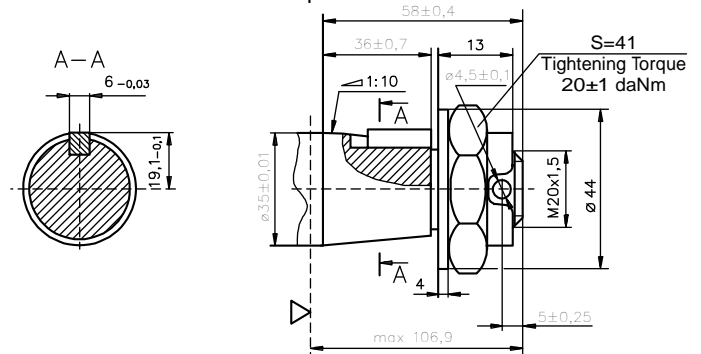

OB - tapered 1:8 SAEJ 501, Parallel key $\frac{5}{16} \times \frac{5}{16} \times 1\frac{1}{4}$ " BS46
Max. Torque 77 daNm

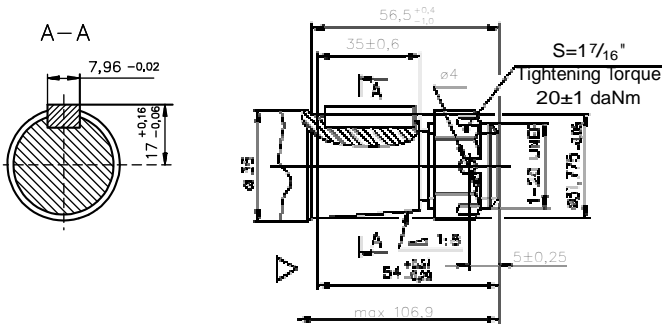

▽ - Motor Mounting Surface

ORDER CODE

| | | | | | | |
|-----|---|---|---|---|---|---|
| | 1 | 2 | 3 | 4 | 5 | 6 |
| R W | | | | | | |

Pos.1 - Displacement code

| | | |
|-----|---|------------------------------|
| 50 | - | 51,5 [cm ³ /rev] |
| 80 | - | 80,3 [cm ³ /rev] |
| 100 | - | 99,8 [cm ³ /rev] |
| 125 | - | 125,7 [cm ³ /rev] |
| 160 | - | 159,6 [cm ³ /rev] |
| 200 | - | 199,8 [cm ³ /rev] |
| 250 | - | 250,1 [cm ³ /rev] |
| 315 | - | 315,7 [cm ³ /rev] |
| 400 | - | 397,0 [cm ³ /rev] |

Pos.2 - Shaft Extensions*

| | | |
|----|---|--|
| CB | - | $\varnothing 32$ straight, Parallel key A10x8x45 DIN6885 |
| KB | - | $\varnothing 35$ tapered 1:10, Parallel key B6x6x20 DIN6885 |
| OB | - | $\varnothing 1\frac{1}{4}$ " tapered 1:8, Parallel key $\frac{5}{16} \times \frac{5}{16} \times 1\frac{1}{4}$ " BS46 |

Pos. 3 - Drain Port

| | | |
|------|---|--------------------|
| omit | - | with drain port |
| 1 | - | without drain port |

Pos. 4 - Ports

| | | |
|------|---|------------------|
| omit | - | BSPP (ISO 228) |
| M | - | Metric (ISO 262) |

Pos. 5 - Special Features (see page 53)

Pos. 6 - Design Series

| | | |
|------|---|-------------------|
| omit | - | Factory specified |
|------|---|-------------------|

NOTE: * The permissible output torque for shafts must not be exceeded!

The hydraulic motors are mangano-phosphatized as standard.

ООО «Кама-Флекс-Гидравлика» (8552) 44-33-58

<http://www.oookfg.narod.ru>

e-mail: kama-hydraulic@narod.ru